

**SKÝRINGAR:**  
ALMENNAR SKÝRINGAR SJÁ TEKN. B000  
BENDING VEGGJA NEMA ANNAD SÉ TEKID FRAM:  
180/200mm ÞYKKIR:  
TVÖFALT NET K10c200 LÖDRÉTT OG K10c250 LÁRÉTT  
150mm ÞYKKIR:  
EINFALT NET K10c200 LÖDRÉTT OG K10c200 LÁRÉTT

JÄRNUN KRINGUM OP ER 2K12 OG JÄRNAFYRIRKOMULAG  
SKV SKÝRINGARBLADI (NEMA ANNAD KOMI FRAM)  
Í INNVEGGJUM KOMA 2K12 Í VEGGENDA

SÉU JÄRNABAKKAR NOTADIR Í STAD VINKLA/U-LYKKJA SKULU  
ÞEIR VALDIR ÞANNIG AD JÄRNAMAGNID SÉ ÞAD SAMA.

PLÖTUSÆTI SKAL VERA AD LÁMARKI 50mm.

EINANGRUNARÞYKKTIR ERU  
-100mm PLASTEINANGRUN UNDIR BOTNPLÖTU, 24kg/m<sup>3</sup>  
-100mm PLASTEINANGRUN NIÐUR MED SÖKKUL

KJARNABORA/SAGA MÁ FYRIR LÖGNUM EF EKKI HEFUR  
VERID GERT FYRIR ÞEIM Í UPPSTEYPU.  
LAGNGAGÖT Í SÖKKLA OG PLÖTUR. SJÁ LAGNATEIKNINGAR.

ATH G.R.F. ÚRTAKI FYRIR LAGNASTOFNA Í SÖKKLA ÞAR SEM  
STOFNAR KOMA  
NIÐUR MED FRAM VEGGJUM OG GETA REKIST Í  
SÖKKULFÆTUR.  
YFIRFARA SKAL ALLAR MÁLSETNINGAR OG HÆÐARKÖTA  
M.T.T TEIKNINGA ARKITEKTA OG GERA HÖNNUDUM VIÐVART  
EF MISRÆMI FINNST.

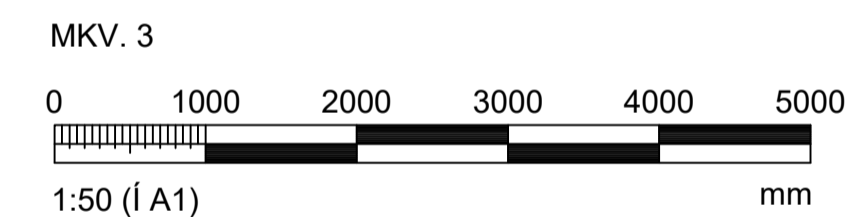

ARITUN HÖNNUNARSTJÓRA: Andri Ingólfsson Kt: 070388-3089

BREYTINGAR			
NR.	DAGS.	BREYTING	SP.
1	08.12.2023	FRUMÚTGÁFA	HÓO

**nne** VERKFRÆÐISTOFA

NNE Verkefndistofa ehf. hl. 460421-0470  
HJEDASMARI 6, 201 KÖPAVOGUR  
hoo@nne.is, SIMI 899-3577 / 899-3077

SAMÞYKKT HÁKON ÖRN ÓMARSSON 300577-3189

VERK  
HRYGGJARÁS 32  
HAFNARFJÖRÐUR  
TEIKNING  
BURÐARVIRKI  
SÖKKLAR OG BOTNPLATA, GRUNNMYND

HANNAÐ	TEIKNAD	YFIRFARID	MJELKVARDI	
HÓO/ SAO	SAÓ/HÓO	HÓO	1:50	/A1
DAGS.	VERK NR.	TEIKNING NR.	UTGAFANR.	
08.12.2023	23038	B000	1	

SÖKKLAR OG BOTNPLATA, GRUNNMYND  
MKV. 3

**SKÝRINGAR:**  
ALMENNAR SKÝRINGAR SJÁ TEIKN. B000  
BENDING VEGGJA NEMA ANNAD SÉ TEKID FRAM:  
180/200mm ÞYKKIR:  
TVÖFALT NET K10c200 LÓDRÉTT OG K10c250 LÁRÉTT  
150mm ÞYKKIR:  
EINFALT NET K10c200 LÓDRÉTT OG K10c200 LÁRÉTT

JÁRNUN KRINGUM OP ER 2K12 OG JÁRNAFYRIRKOMULAG  
SKV SKÝRINGARBLADI (NEMA ANNAD KOMI FRAM)  
Í INNVEGGJUM KOMA 2K12 Í VEGGENDA

SÉU JÁRNABAKKAR NOTADIR Í STAÐ VINKLA/U-LYKKJA SKULU  
ÞEIR VALDIR ÞANNIG AD JÁRNAMAGNID SÉ ÞAD SAMA.

PLÖTUSÆTI SKAL VERA AD LÁMARKI 50mm.

EINANGRUNARÞYKKTIR ERU  
-100mm PLASTEINGRUN UNDIR BOTNPLÖTU, 24kg/m<sup>3</sup>  
-100mm PLASTEINGRUN NIÐUR MED SÖKKUL

KJARNABORA/SAGA MÁ FYRIR LÖGNUM EF EKKI HEFUR  
VERID GERT FYRIR ÞEIM Í UPPSTEYPU.  
LAGNGAGÓT Í SÖKKLA OG PLÖTUR, SJÁ LAGNATEIKNINGAR.

ATH G.R.F. ÚRTAKI FYRIR LAGNASTOFNA Í SÖKKLA ÞAR SEM  
STOFNAR KOMA  
NIÐUR MED FRAM VEGGJUM OG GETA REKIST Í  
SÖKKULFÆTUR.  
YFIRFARA SKAL ALLAR MÁLSETNINGAR OG HÆÐARKÓTA  
M.T.T TEIKNINGA ARKITEKTA OG GERA HÖNNUÐUM VIÐVART  
EF MISRÆMI FINNST.

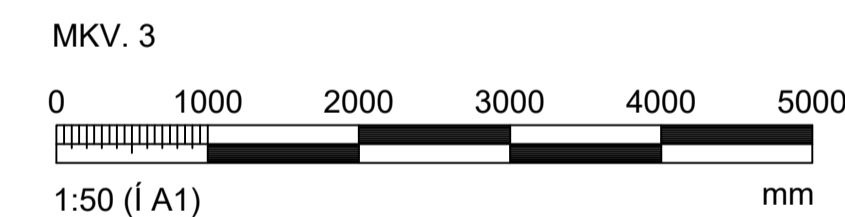
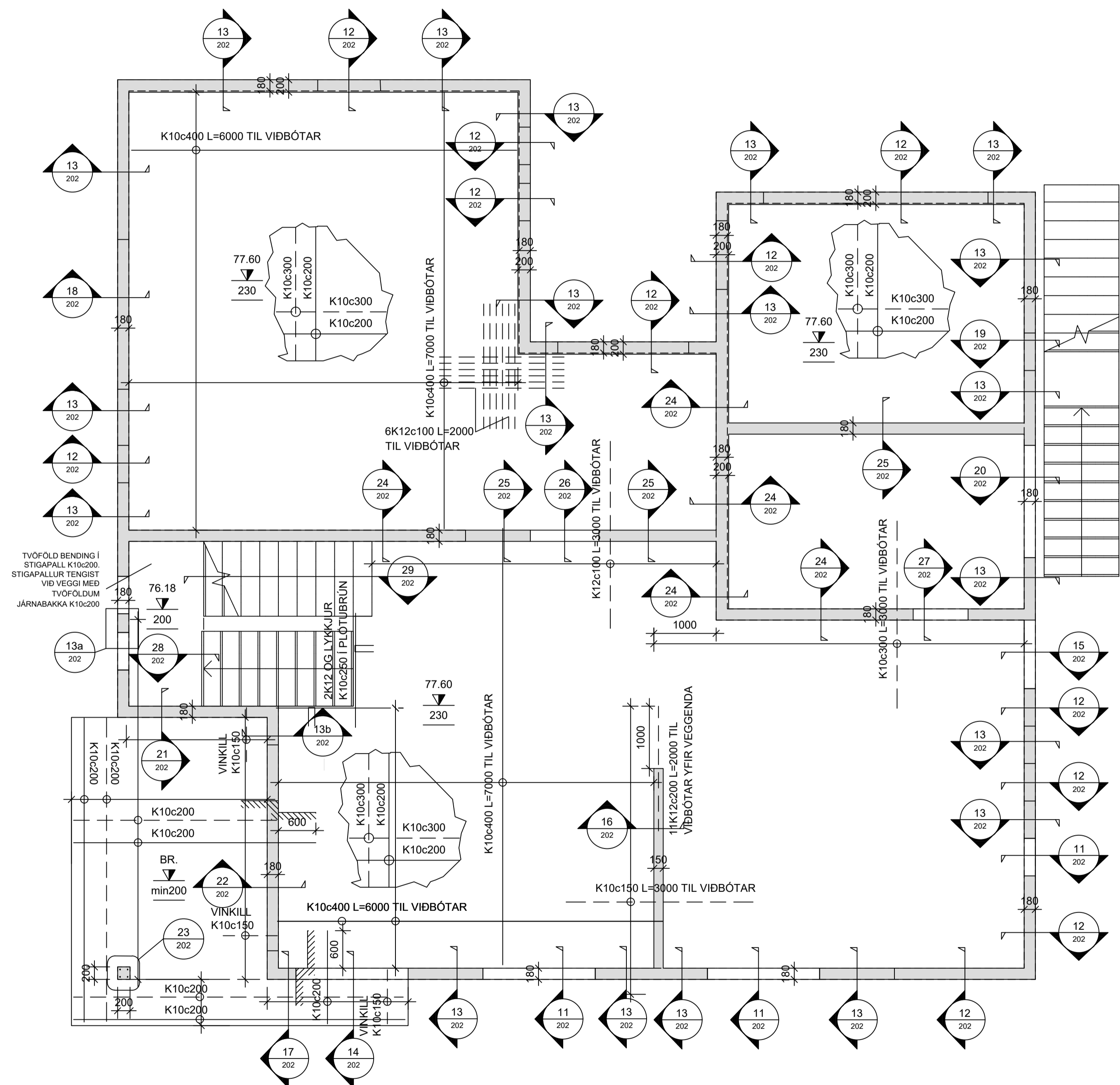

ARITUN HÖNNUNARSTJÓRA: Andri Ingólfsson Kt: 070388-3089

BREYTINGAR			
NR.	DAGS.	BREYTINGA	SP.
1	08.12.2023	FRUMÚTGÁFA	HÓO

**nne** VERKFRÆÐISTOFA

NNE Verkefnaeistofa ehf. hl. 460421-0470  
HÆÐASMÁRI 6, 201 KÓPANGULUR  
hoo@nne.is, SÍMI 899-3577 / 899-3077

SAMÞYKKT HÁKON ÖRN ÓMARSSON 300577-3189

VERK  
HRYGGJARÁS 32  
HAFNARFJÖRÐUR  
TEIKNING  
BURÐARVIRKI  
LOFTAPLATA 1 HÆÐAR, GRUNNMYND

HANNAÐ	TEIKNAD	YFIRFARID	MJELKVARDI	
HÓO/ SAO	SAÓ/HÓO	HÓO	1:50	/A1
08.12.2023	23038	B000		1

LOFTAPLATA 1 HÆÐAR, GRUNNMYND  
MKV. 3

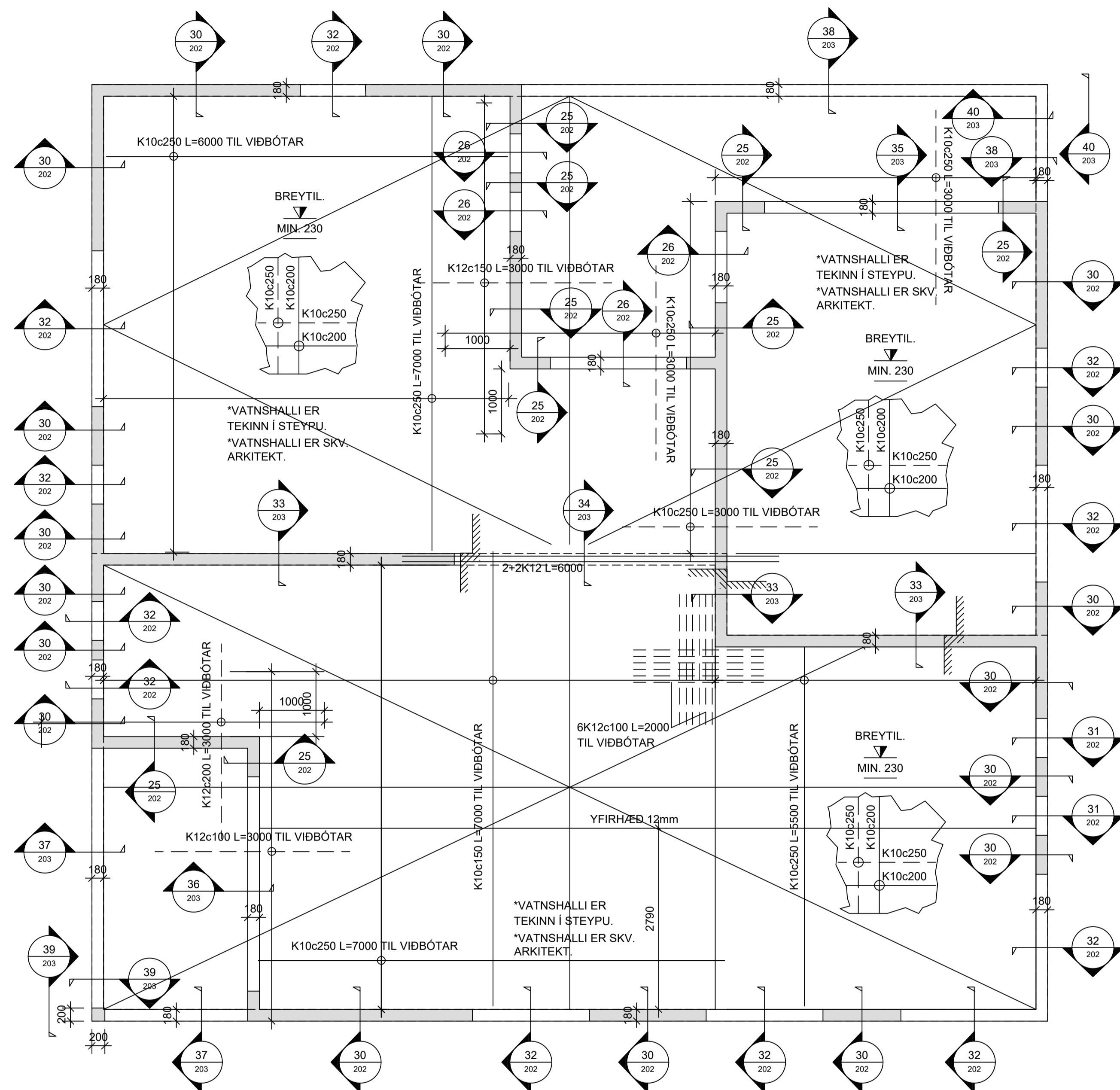

**SKÝRINGAR:**

ALMENNAR SKÝRINGAR SJÁ TEKN. B000  
BENDING VEGGJA NEMA ANNAD SÉ TEKID FRAM:  
180/200mm ÞYKKIR:  
TVOFALT NET K10c200 LÖDRÉTT OG K10c250 LÁRÉTT  
150mm ÞYKKIR:  
EINFALT NET K10c200 LÖDRÉTT OG K10c200 LÁRÉTT

JÄRNUN KRINGUM OP ER 2K12 OG JÄRNAFYRIRKOMULAG  
SKV SKÝRINGARBLADI (NEMA ANNAD KOMI FRAM)  
Í INNVEGGJUM KOMA 2K12 Í VEGGENDA

SÉU JÄRNABAKKAR NOTADIR Í STAD VINKLA/U-LYKKJA SKULU  
ÞEIR VALDIR ÞANNIG AD JÄRNAMAGNIÐ SÉ ÞAÐ SAMA.

PLÖTUSÆTI SKAL VERA AD LÄMARKI 50mm.

EINANGRUNARÞYKKTIR ERU  
-100mm PLASTEINANGRUN UNDIR BOTNPLÖTU, 24kg/m<sup>3</sup>  
-100mm PLASTEINANGRUN NIÐUR MED SÖKKUL

KJARNBORASAGA MÁ FYRIR LÖGNUM EF EKKI HEFUR  
VERID GERT FYRIR ÞEIM Í UPPSTEYPU.  
LAGNGAGÖT Í SÖKKLA OG PLÖTUR, SJÄ LAGNATEIKNINGAR.

ATH G.R.F. ÚRTAKI FYRIR LAGNASTOFNA Í SÖKKLA ÞAR SEM  
STOFNAR KOMA  
NIÐUR MED FRAM VEGGJUM OG GETA REKIS Í  
SÖKKULFÆTUR.

YFIRFARA SKAL ALLAR MÄLSETNINGAR OG HÄEDARKÖTA  
M.T.T TEIKNINGA ARKITEKTA OG GERA HÖNNUDUM VIÐVART  
EF MISRÄMI FINNST.

MKV. 3

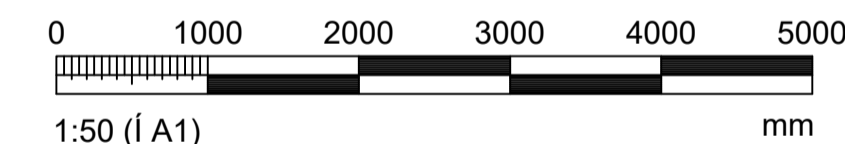

LOFTAPLATA 2 HÆÐAR/ÞAKVIRKI, GRUNNMYND  
MKV. 3

ARITUN HÖNNUNARSTJÖRA: Andri Ingólfsson Kt: 070388-3089

BREYTINGAR			
NR.	DAGS.	BREYTING	SÞ.
1	08.12.2023	FRUMÚTGÁFA	HÖO

**nne** VERKFRÆÐISTOFA

NNE Verkefrafæðistofa ehf. hl. 460421-0470  
HÆDASMARI 6, 201 KÖPAVOGUR  
hoo@nne.is, SÍMI 899-3577 / 899-3077

SAMÞYKKT HÁKON ÖRN ÓMARSSON 300577-3189

VERK  
HRYGGJARÁS 32  
HAFNARFJÖRÐUR  
TEIKNING  
BURÐARVIRKI  
LOFTAPLATA 2 HÆÐAR/ÞAKVIRKI GRUNNMYND

HANNAÐ	TEIKNAD	YFIRFARID	MÆLIKVARÐI	
HÖO/ SAO	SAÓ/HÓO	HÓO	1:50	/A1
08.12.2023	23038	B000		1

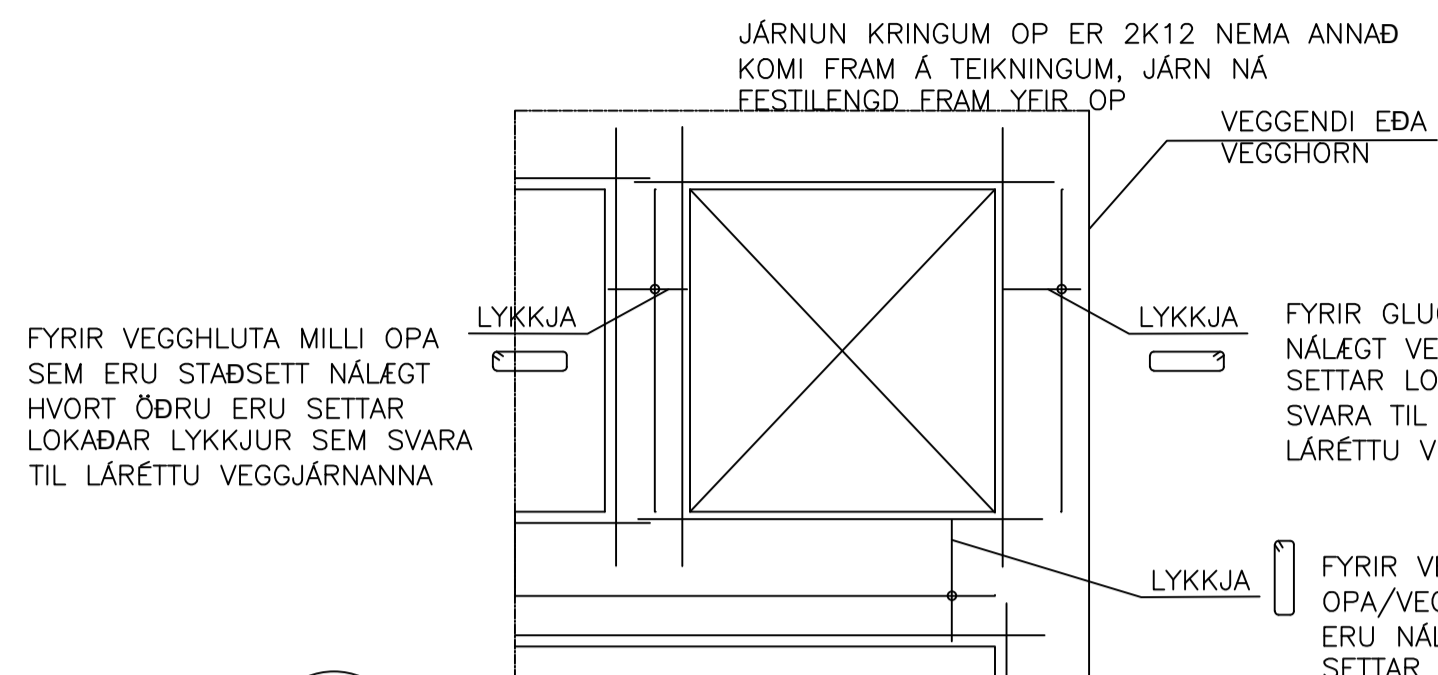

**K0** ÁSYND Á VEGG - JÄRNUN VEGGHLUTA  
Mkv. 2

FYRIR GLUGGA-/HURDAOP NÁLÉGT VEGGENDUM ERU SETTAR LOKAÐAR LYKKJUR SEM SVARA TIL LÓÐRÉTTU EDA LÁRÉTTU VEGGJÄRNANNA

FYRIR VEGGHLUTA/BITA MILLI OPA/VEGGBRÚNA SEM STAÐSETT ERU NÁLÉGT HVORT ÖÐRU ERU SETTAR LOKAÐAR LYKKJUR SEM SVARA TIL LÓÐRÉTTU VEGGJÄRNANNA

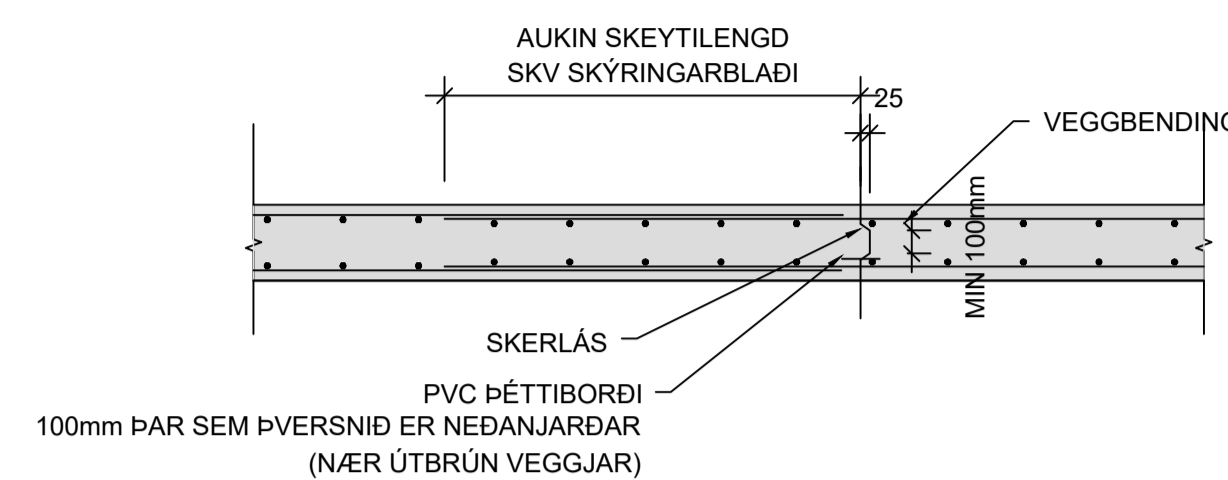

**K1** LÁRÉTT KENNISNIÐ - SKERLÁS Í 200/250mm VEGG  
Mkv. 2

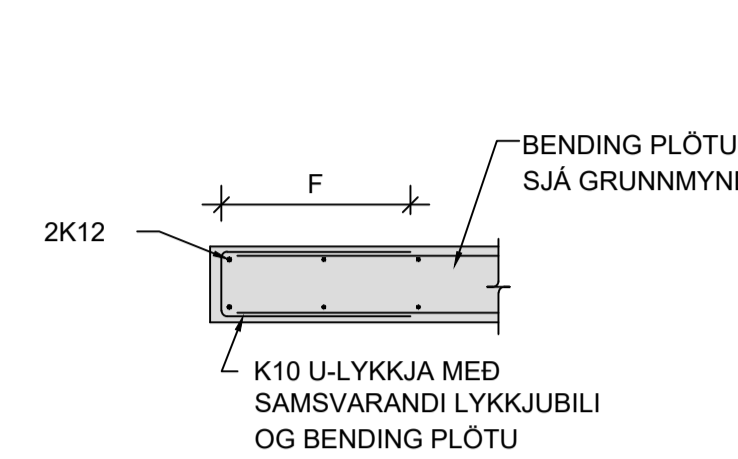

**K2** LÓÐRÉTT KENNISNIÐ - PLÖTUBRÚN  
Mkv. 2

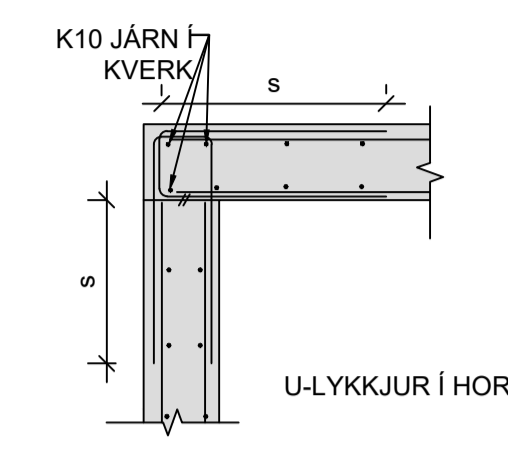

**K3** LÁRÉTT KENNISNIÐ - VEGGHORN  
Mkv. 2

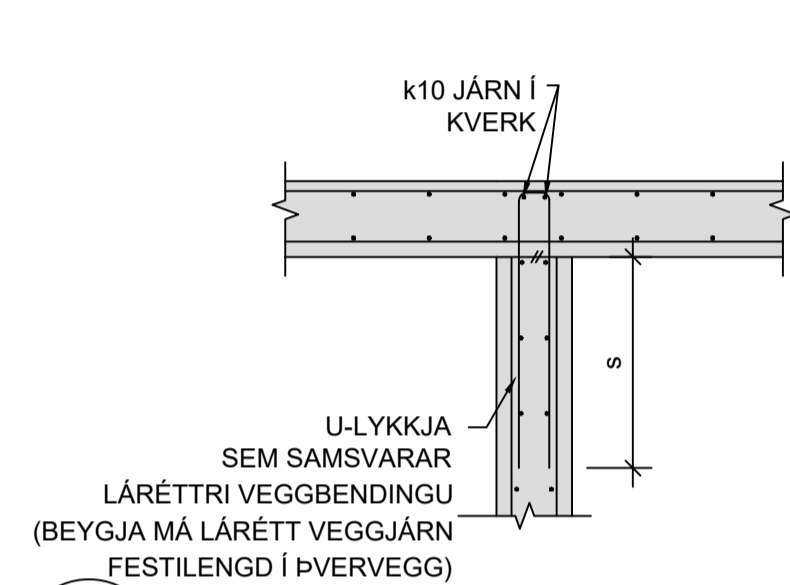

**K4** LÁRÉTT KENNISNIÐ - VEGGMÓT  
Mkv. 2

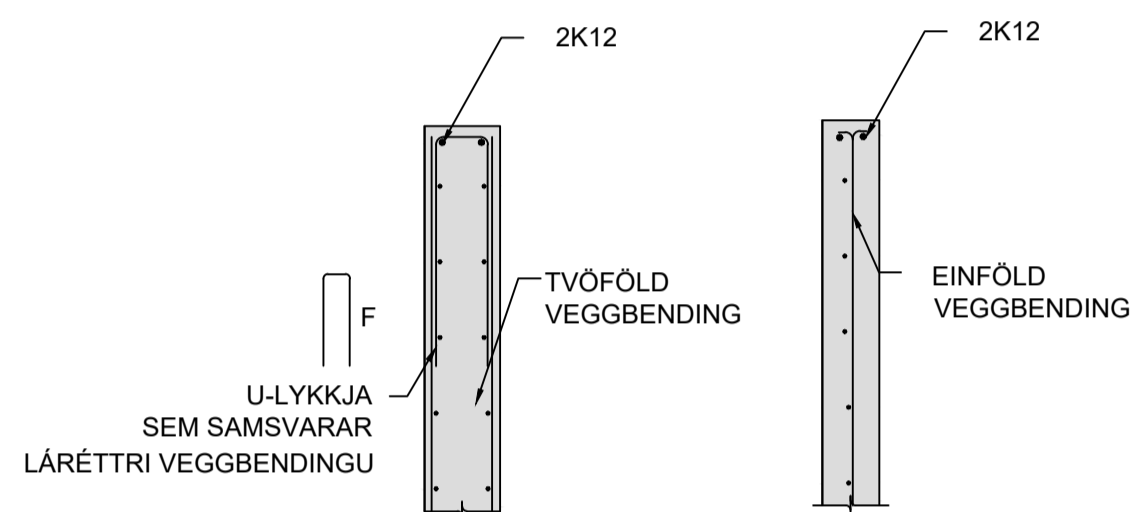

**K5** LÁRÉTT KENNISNIÐ - VEGGENDI TVÖFÖLD BENDING OG EINFÖLD VEGGBENDING  
Mkv. 2

SÉ EKKI ANNARS GETIÐ KOMI AUKALEGA JÄRN UMHVERFIS GLUGGA, HURDIR OG OP Í PLÖTUM OG VEGGJUM ER SVARA TIL ÞEIRRA JÄRNA SEM KLIPPT ERU Í SUNDUR, ÞÓ ALDREI MINNA EN 2 K12.

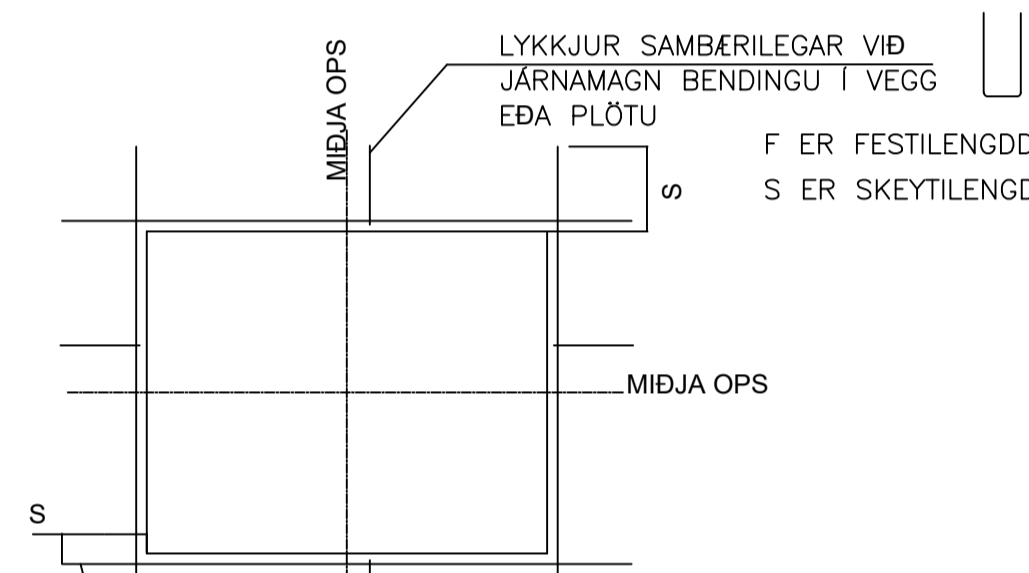

**K6** JÄRNUN KRNGUM OP  
Mkv. 2

SETJA SKAL AUKAJÄRN EINS NÁLÉGT OPI OG HÆGT ER. (HELMINGUR JÄRNA SEM SKERAST Í SUNDUR VEGNA OPS).

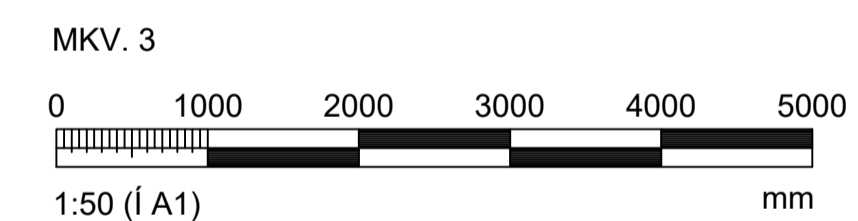

ARITUN HÖNNUNARSTJÓRA: Andri Ingólfsson Kt: 070388-3089

NR.	DAGS.	BREYTING	SÞ.
1	08.12.2023	FRUMÚTGÁFA	HÓO

**nne** VERKFRÆÐISTOFA

NNE Verfræðistofa ehf. hl. 460421-0470  
HÆDASMARI 6, 201 KÓPAVOGUR  
hoo@nne.is, Sími 899-3577 / 899-3077

SAMPYKKT HÁKON ÖRN ÓMARSSON 300577-3189

VERK  
HRYGGJARÁS 32  
HAFNARFJÖRÐUR  
TEIKNING  
BURÐARVIRKI  
SNÍÐ OG DEILI

HANNAÐ	TEIKNAD	YFIRFARID	MÆLIKVARÐI
HÓO/SAO	SAÓ/HÓO	HÓO	1:50
			/A1
DAGS.	VERK NR.	TEIKNING NR.	ÚTGAFANR.
08.12.2023	23038	B200	1

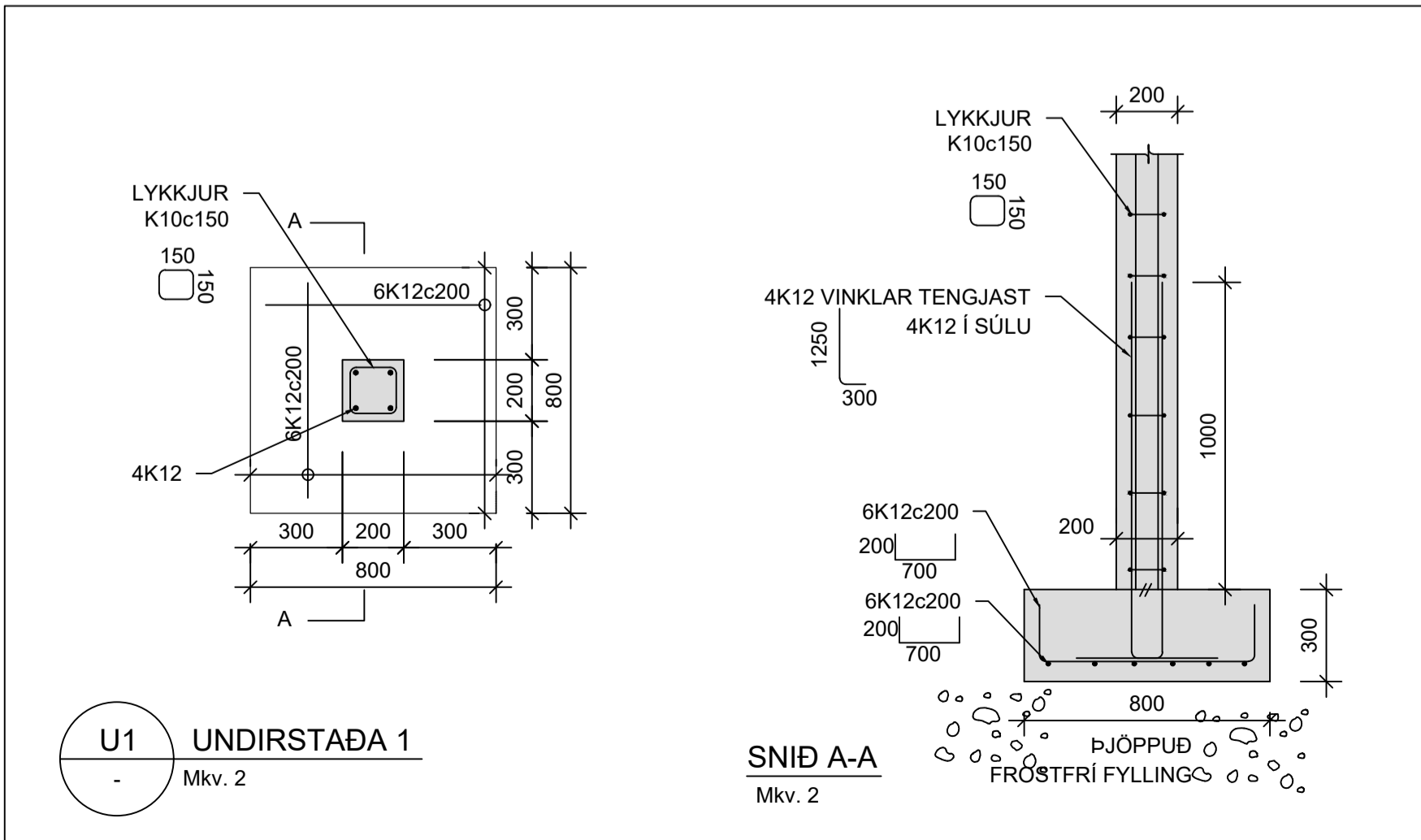
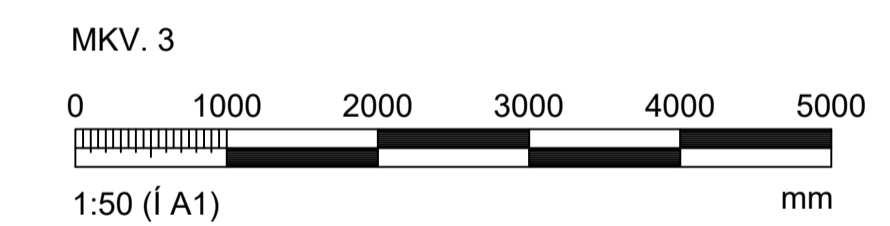
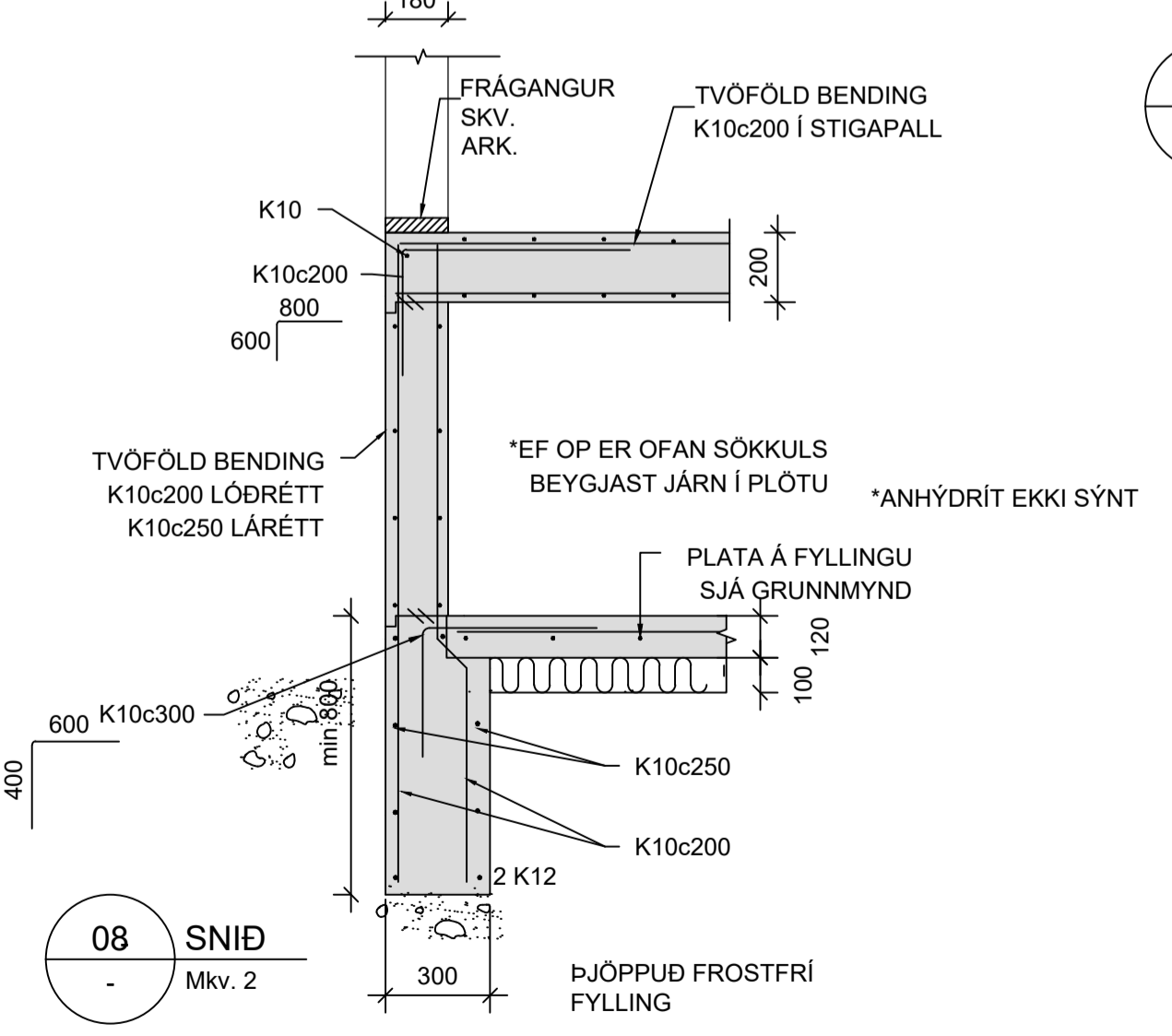
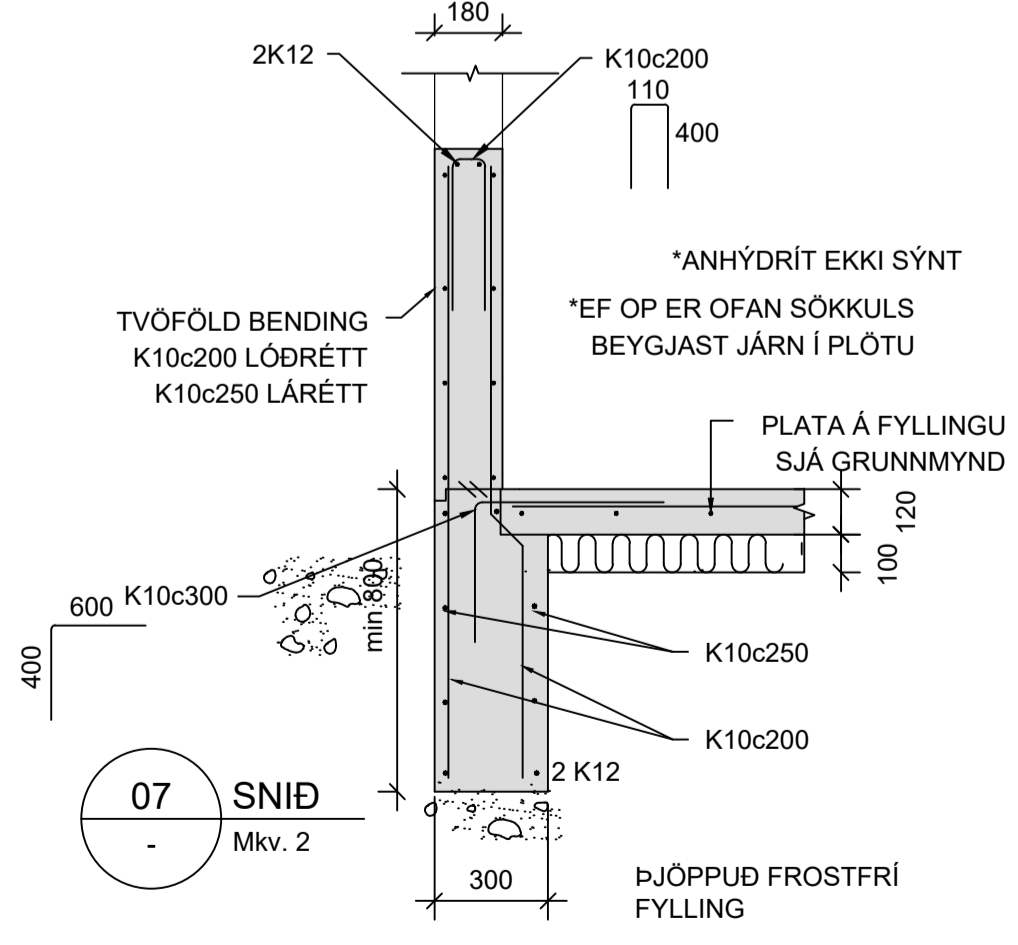
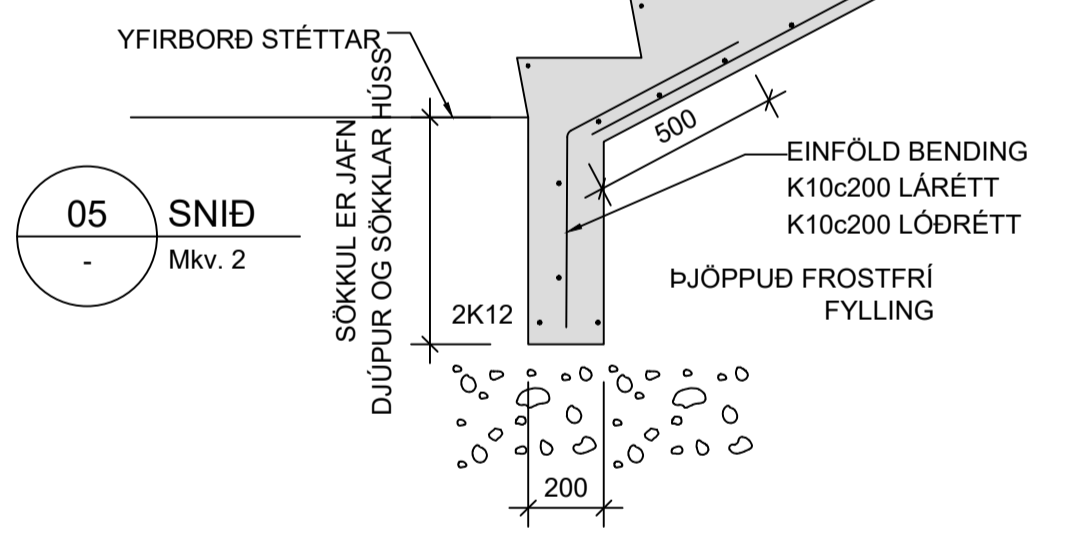
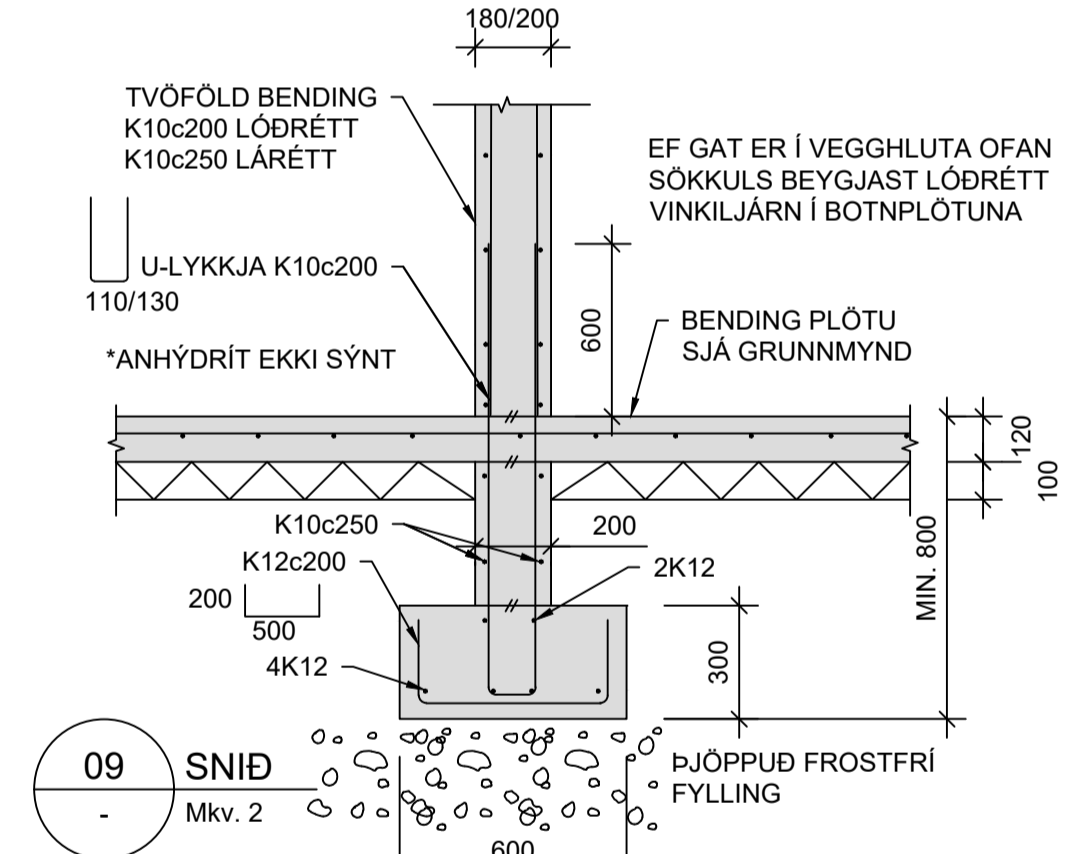
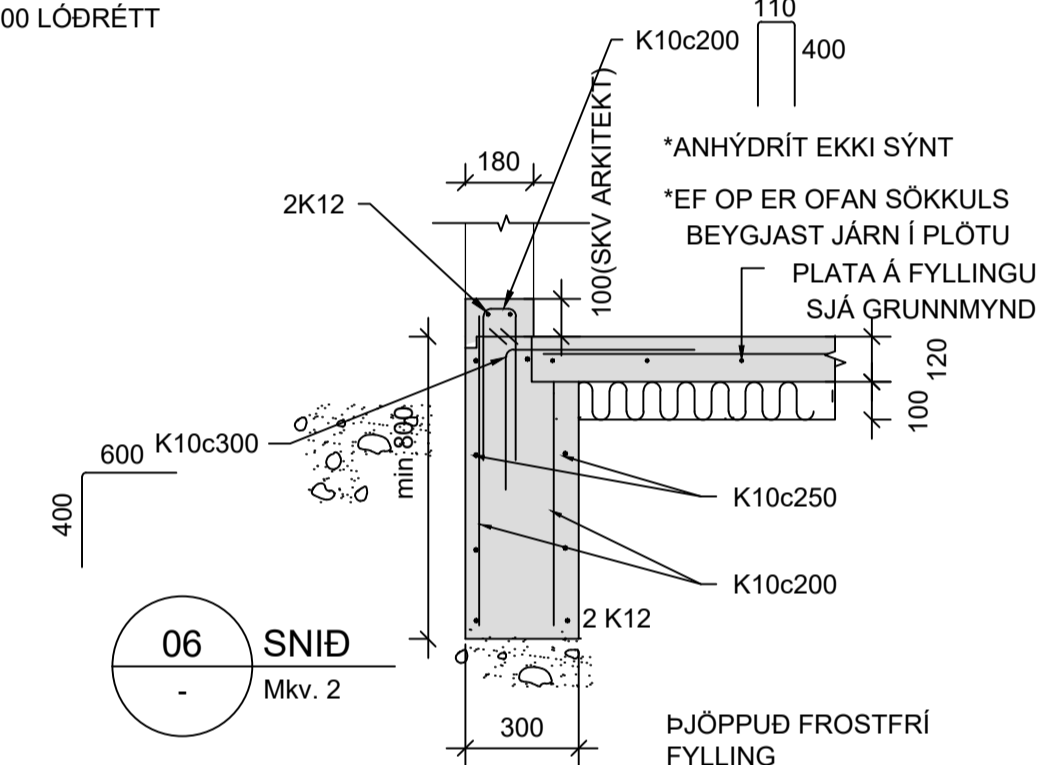
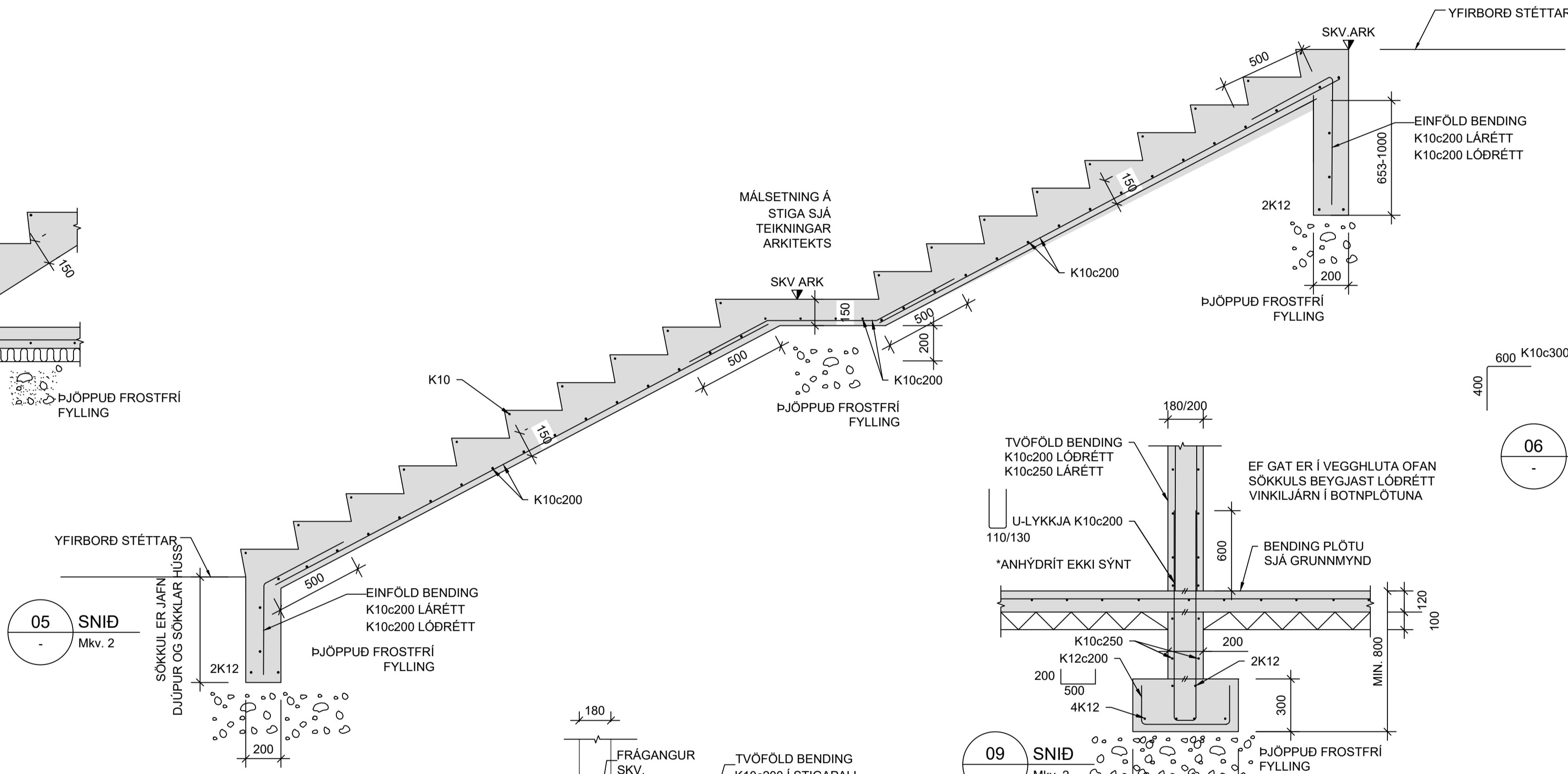
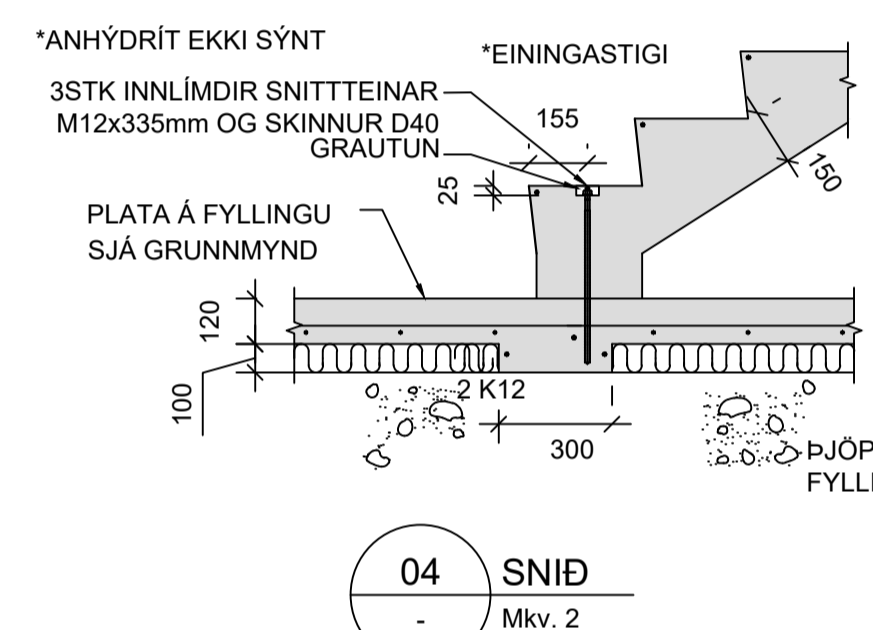
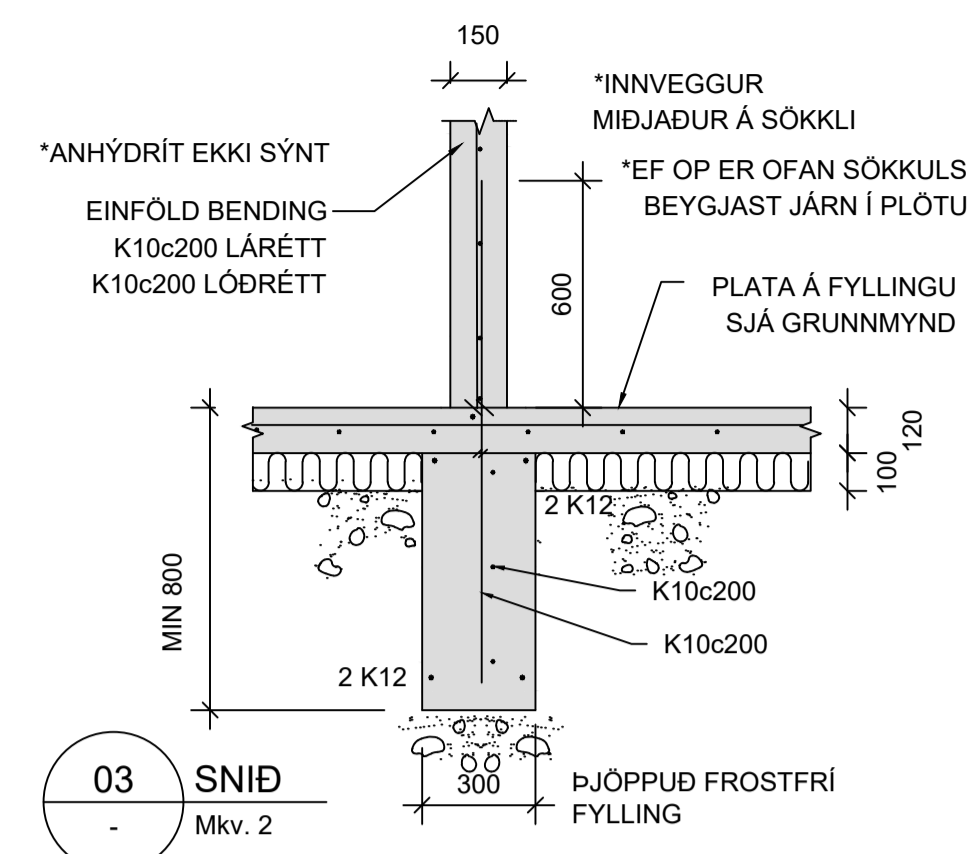
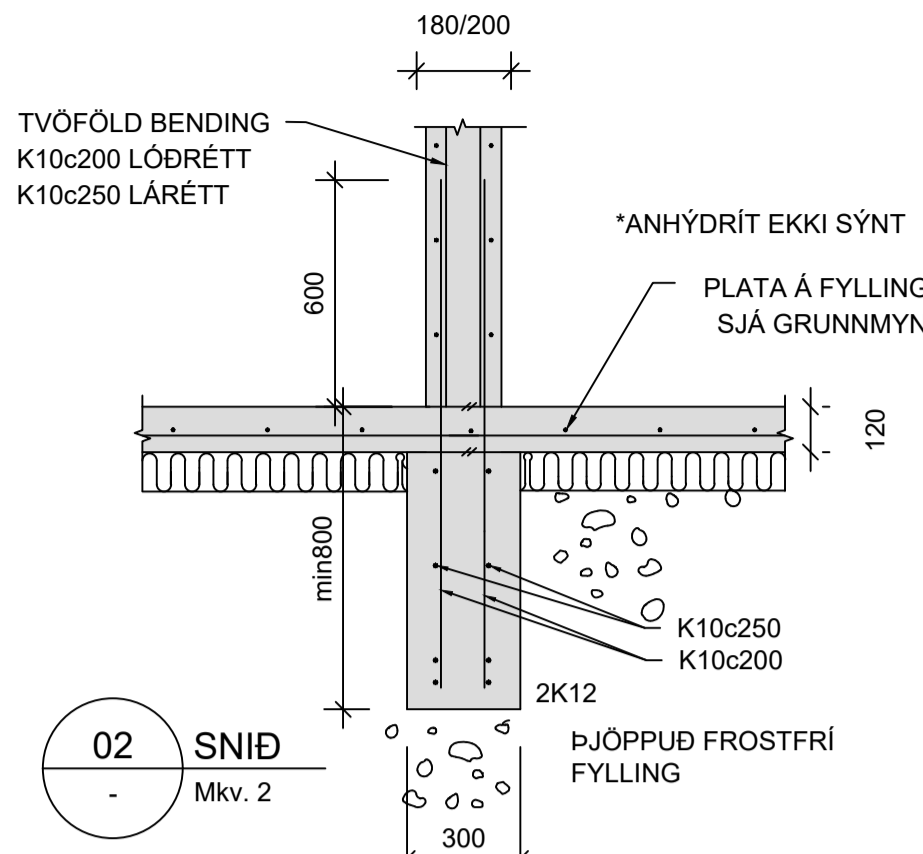
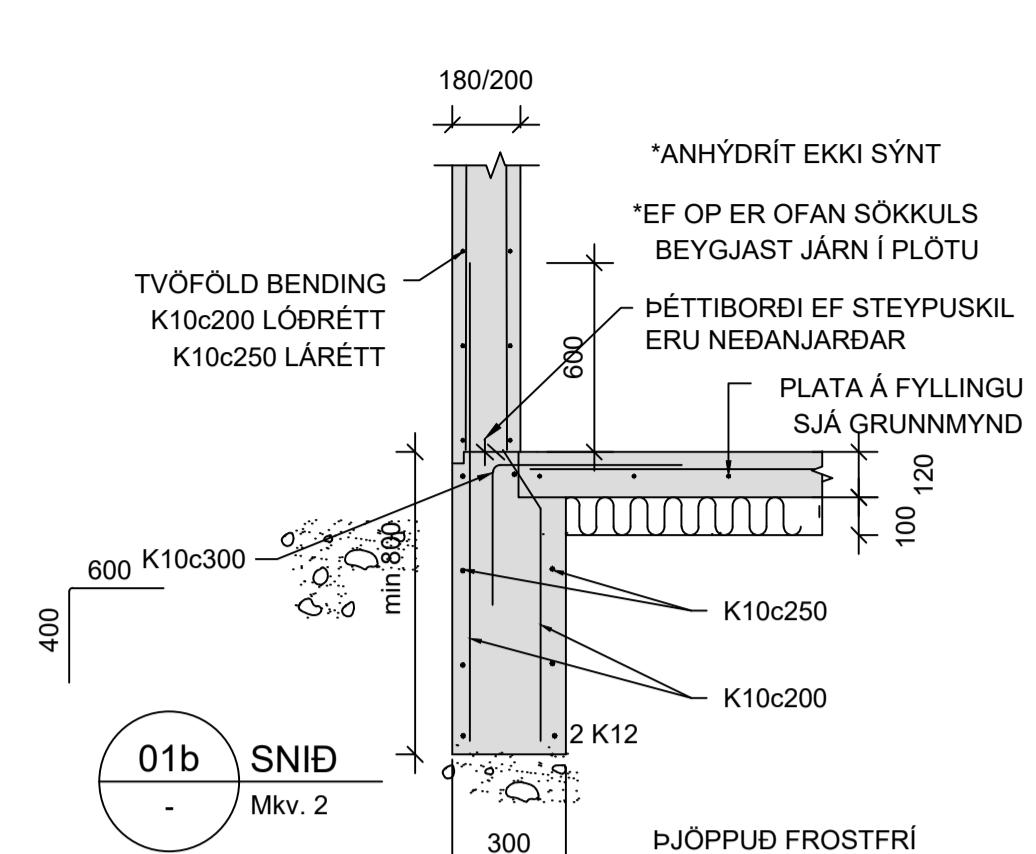
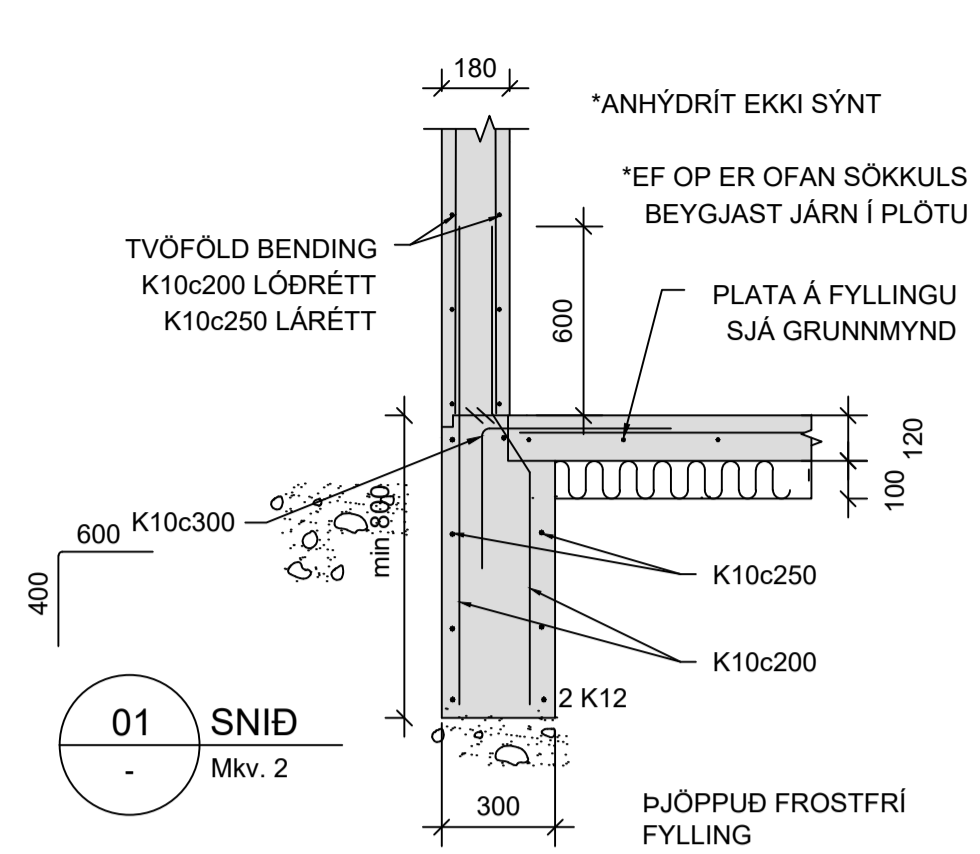

ARITUN HÖNNUNARSTJÓRA: Andri Ingólfsson Kt: 070388-3089

BREYTINGAR	NR.	DAGS.	BREYTING	Sp.
	1	08.12.2023	FRUMÚTGÁFA	HÓO

**ÞNE VERKFRÆÐISTOFA**

ÞNE Verkefnaðstofa ehf. hl. 460421-0470  
HÉÐASMARI 6, 201 KÖPAVOGUR  
hoo@þne.is, SÍMI 899-3577 / 899-3077

SAMPYKKT HÁKON ÖRN ÓMARSSON 300577-3189

VERK  
HRYGGJARÁS 32  
HAFNARFJÖRÐUR  
TEIKNING  
BURÐARVIRKI  
SNIB OG DEILI

HANNAÐ	TEIKNAD	YFIRFARID	MÆLIKVARÐI
HÓO/ SAO	SAÓ/HÓO		1:50
DAGS.	VERK NR.	TEIKNING NR.	UTGAFANR.
08.12.2023	23038	B201	1

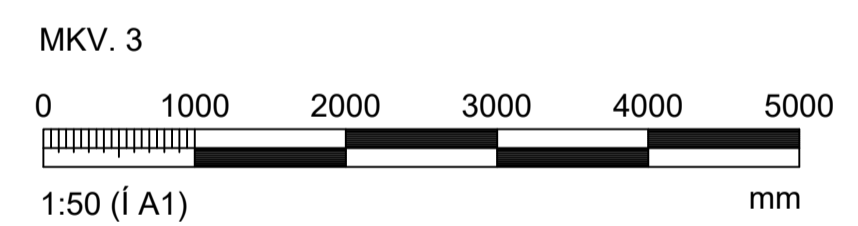
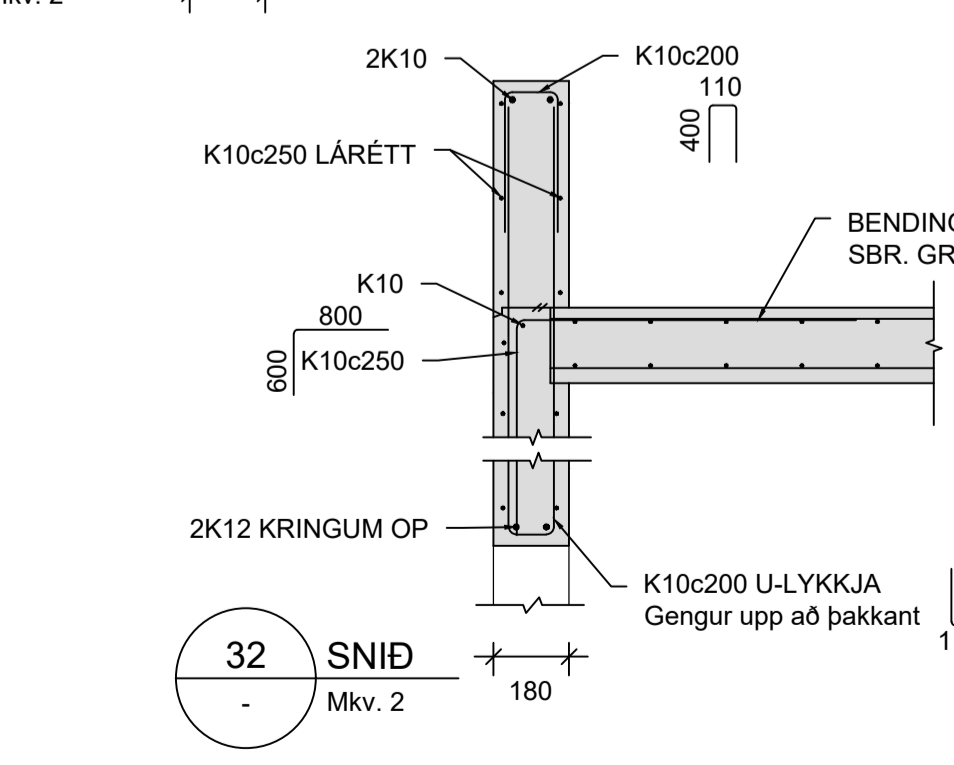
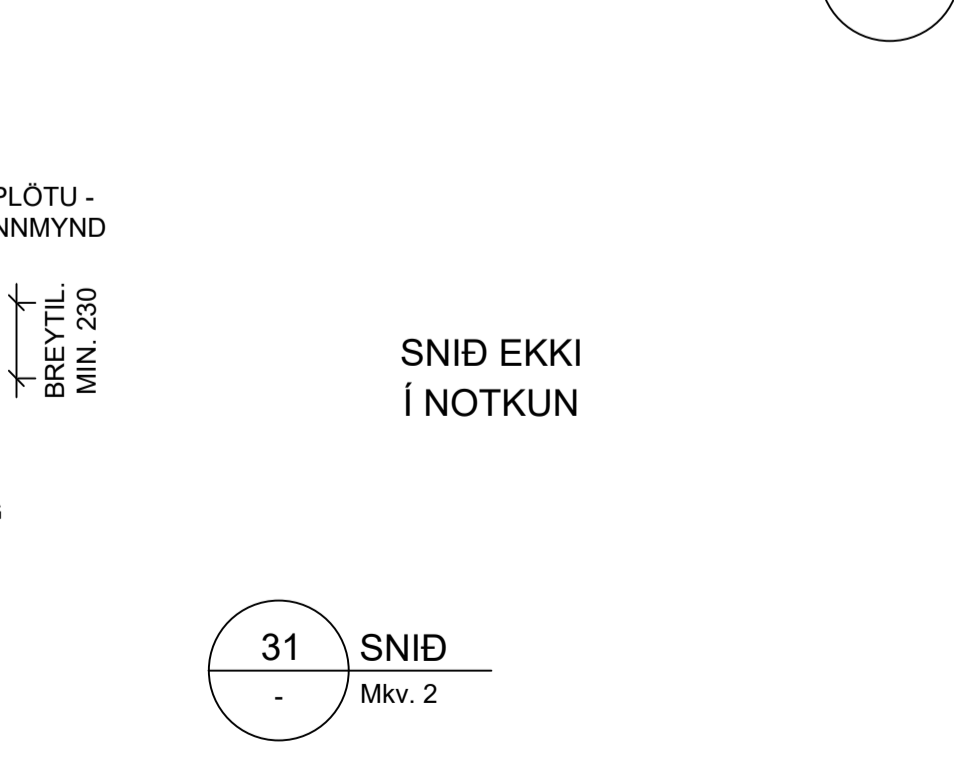
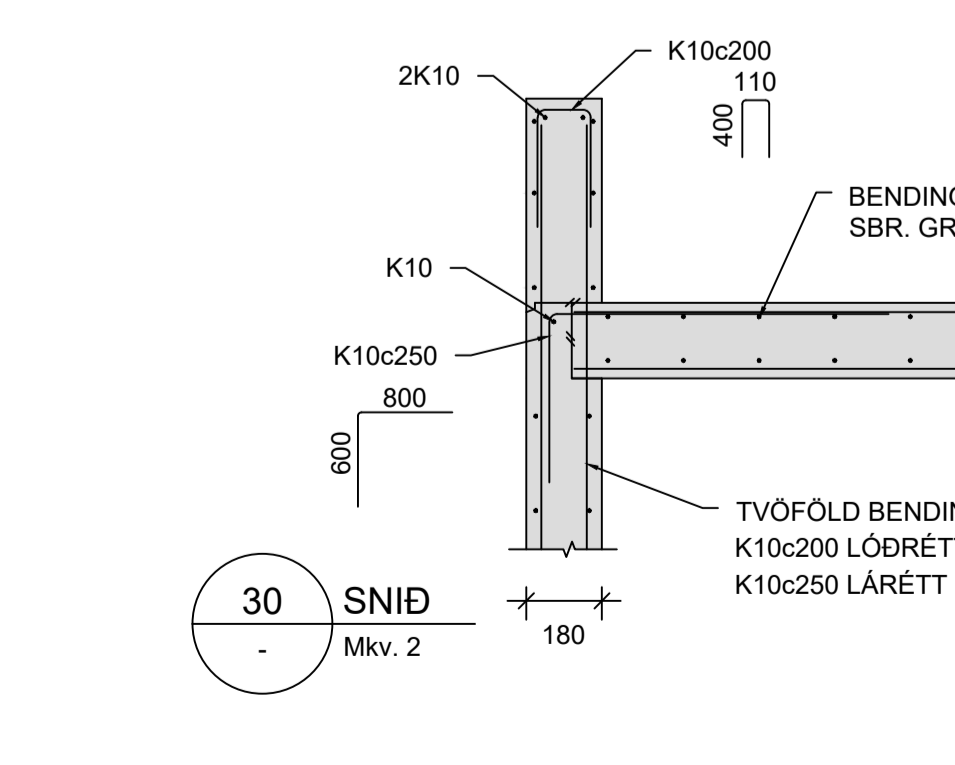
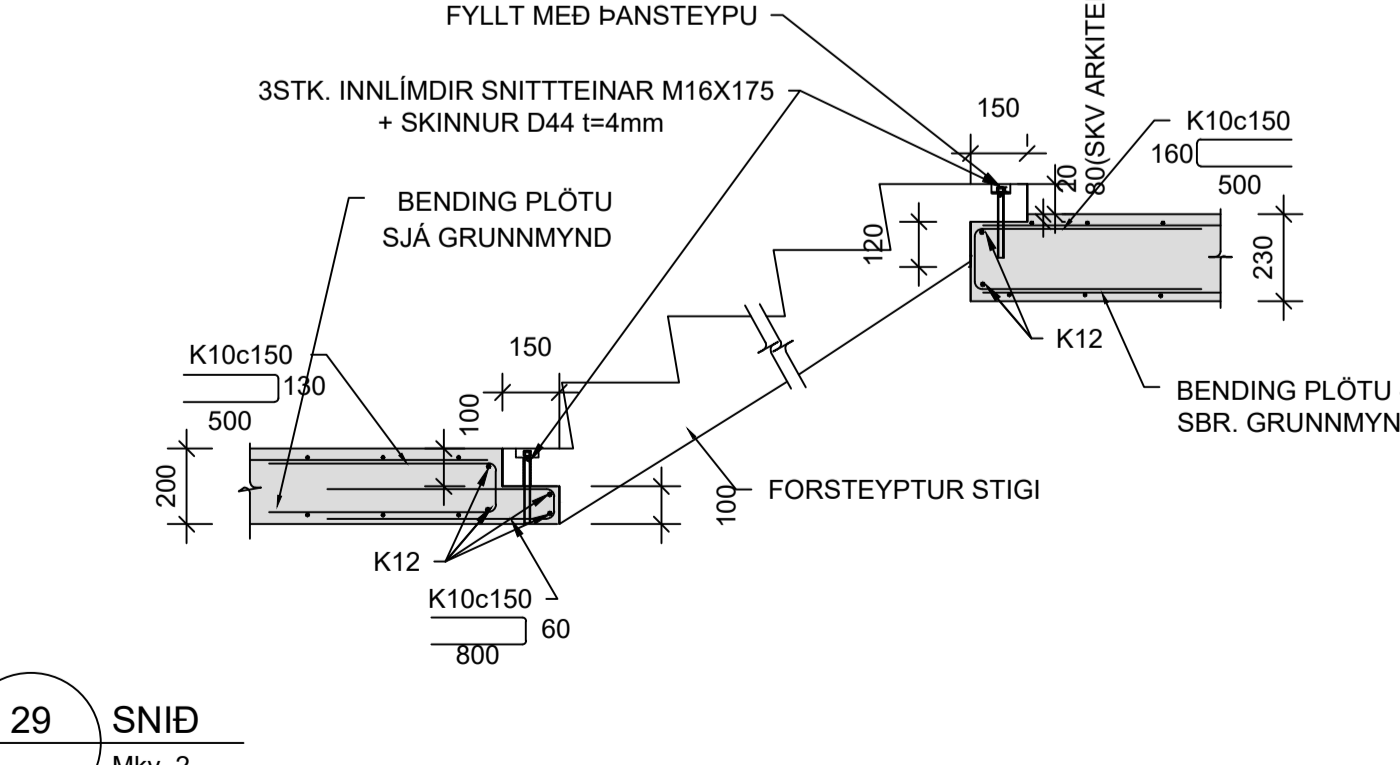
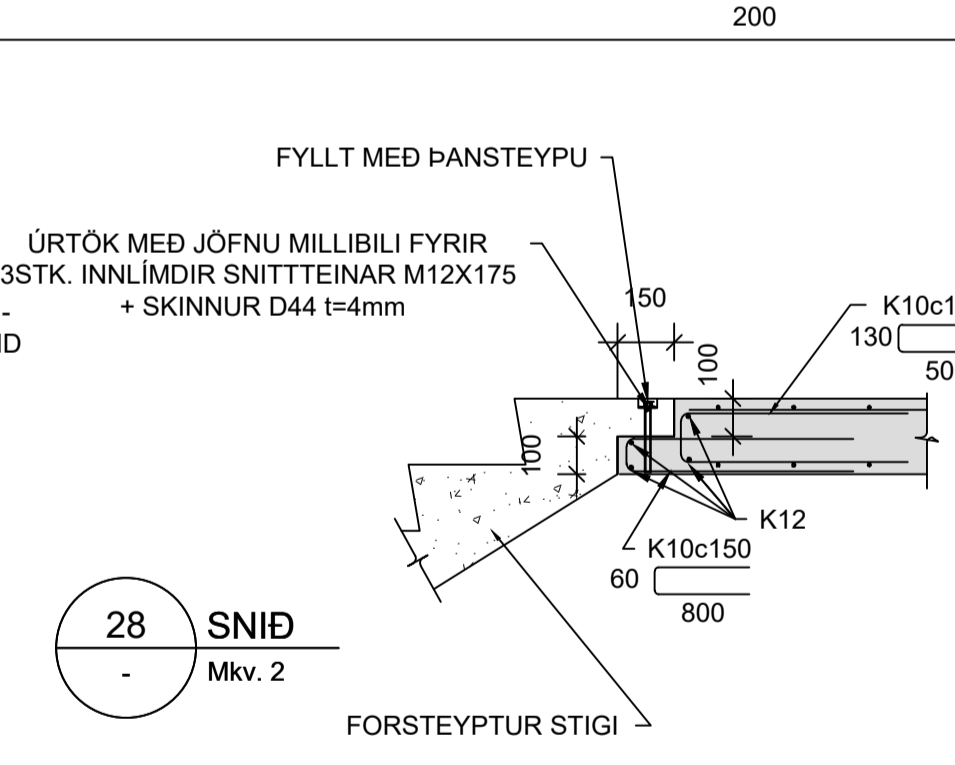
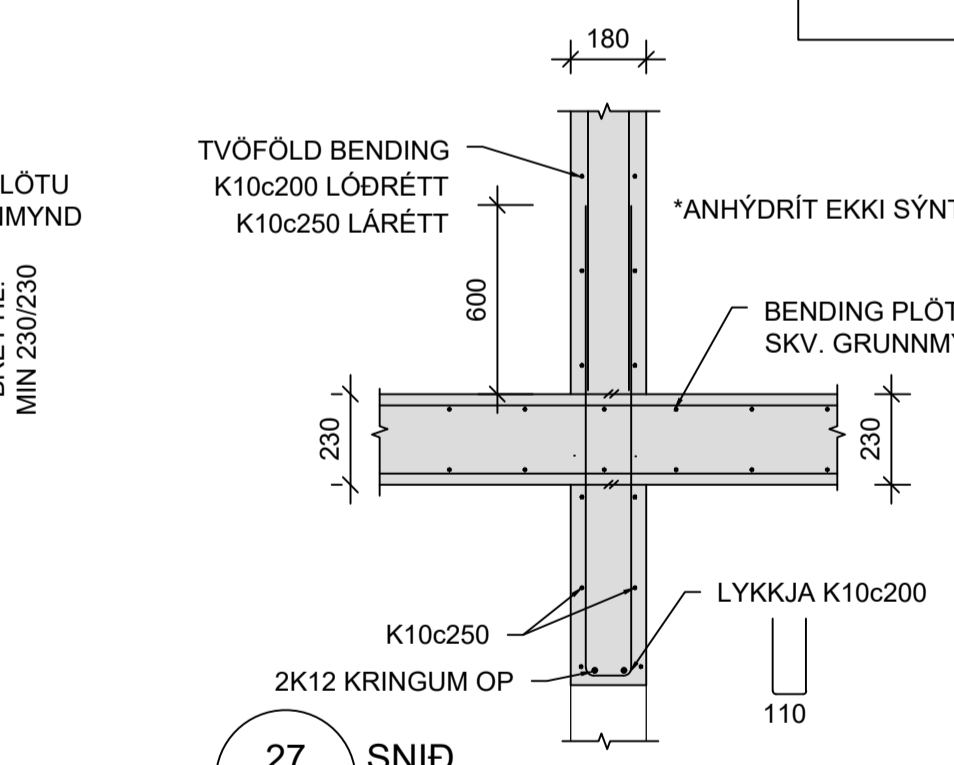
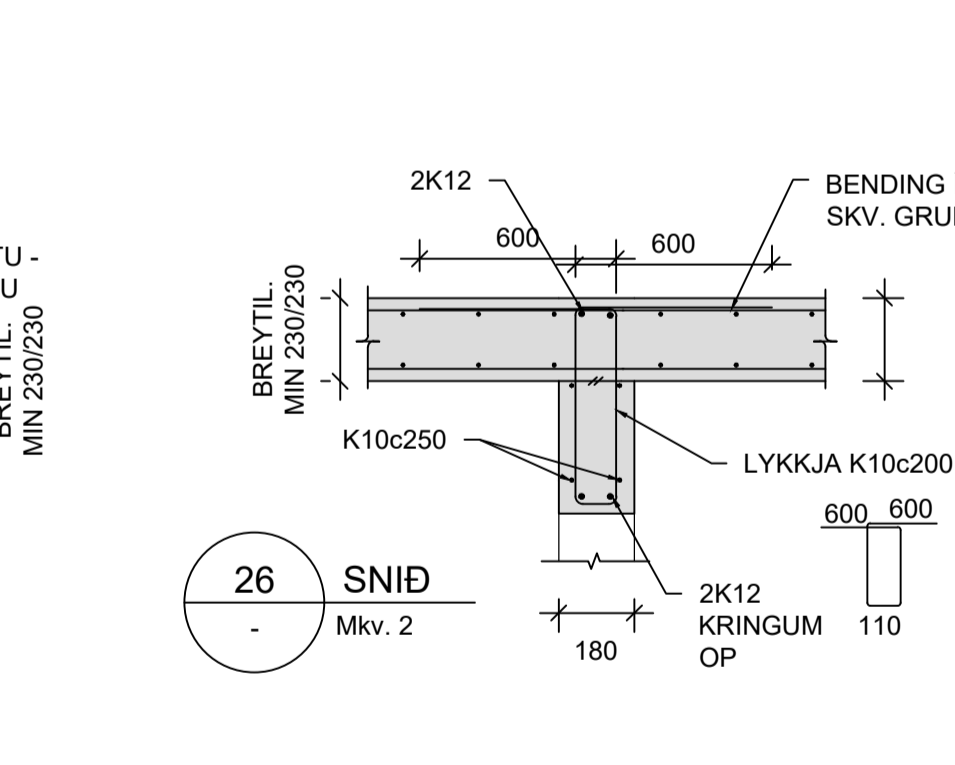
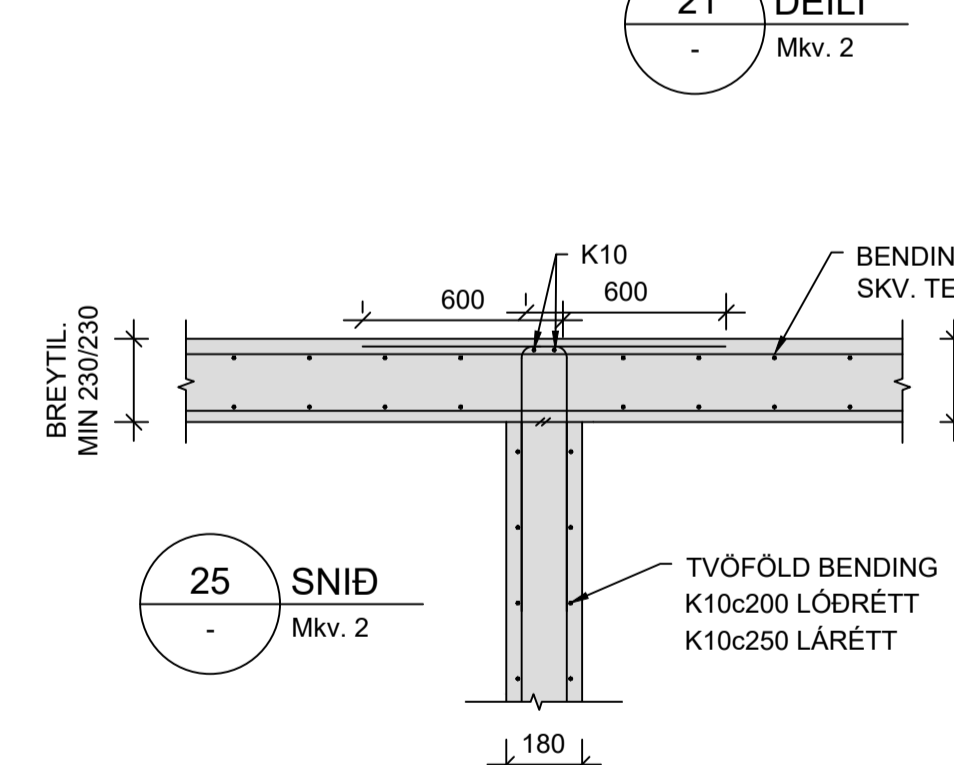
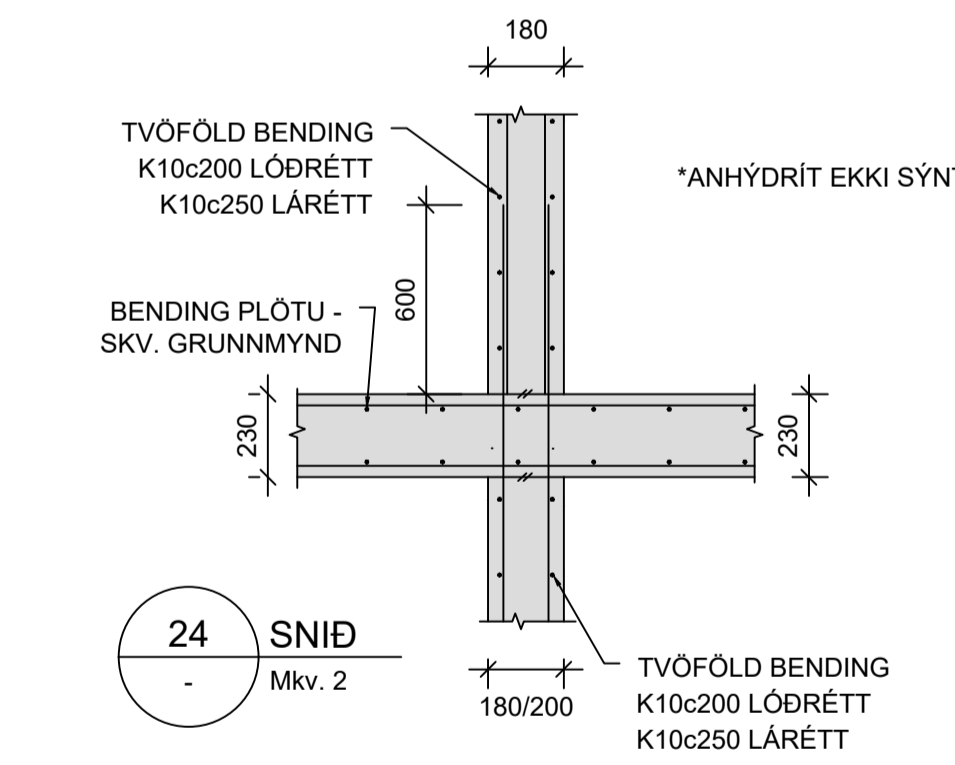
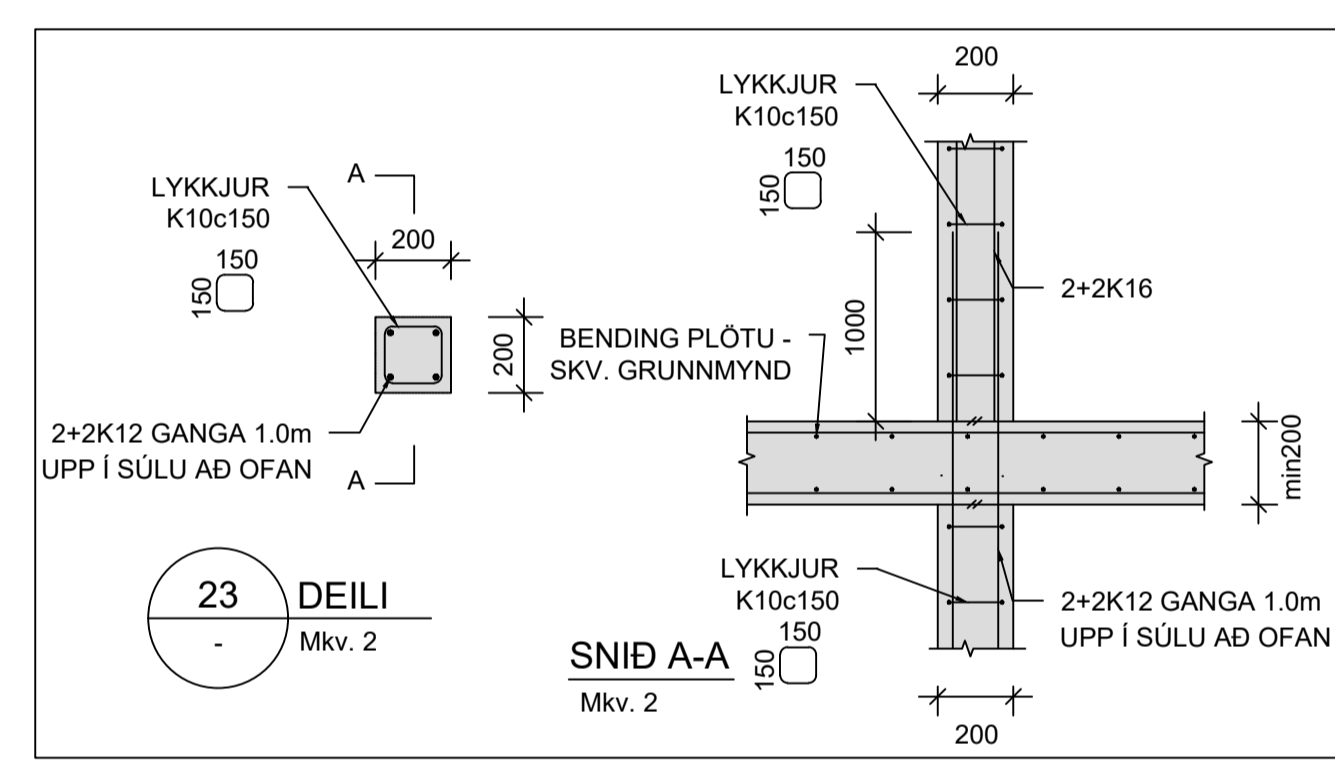
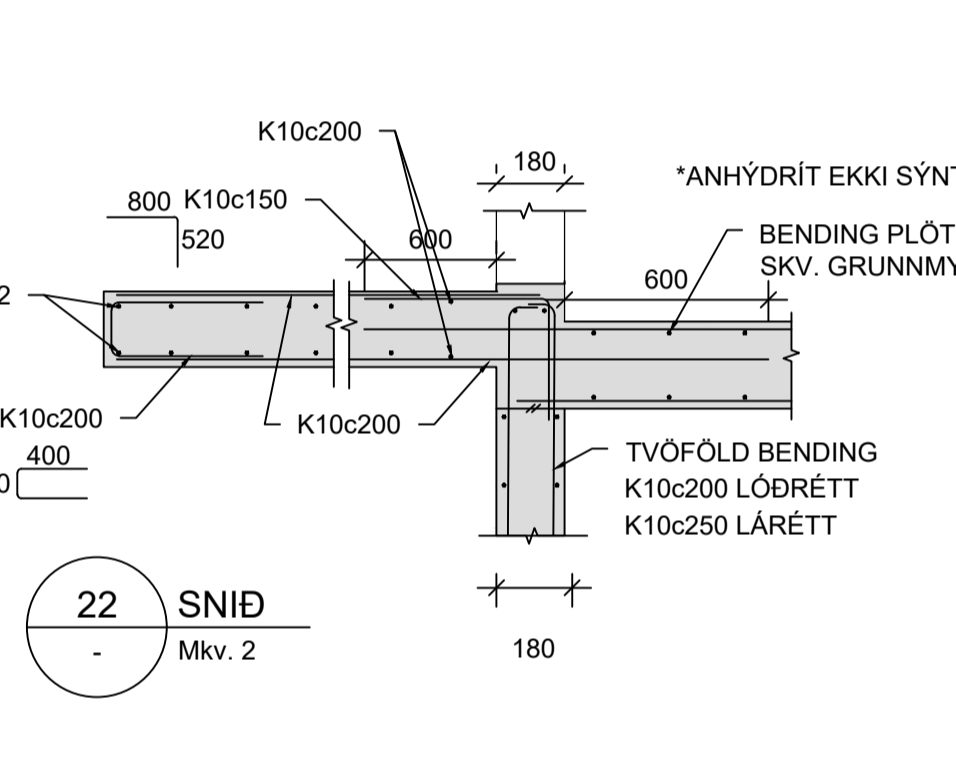
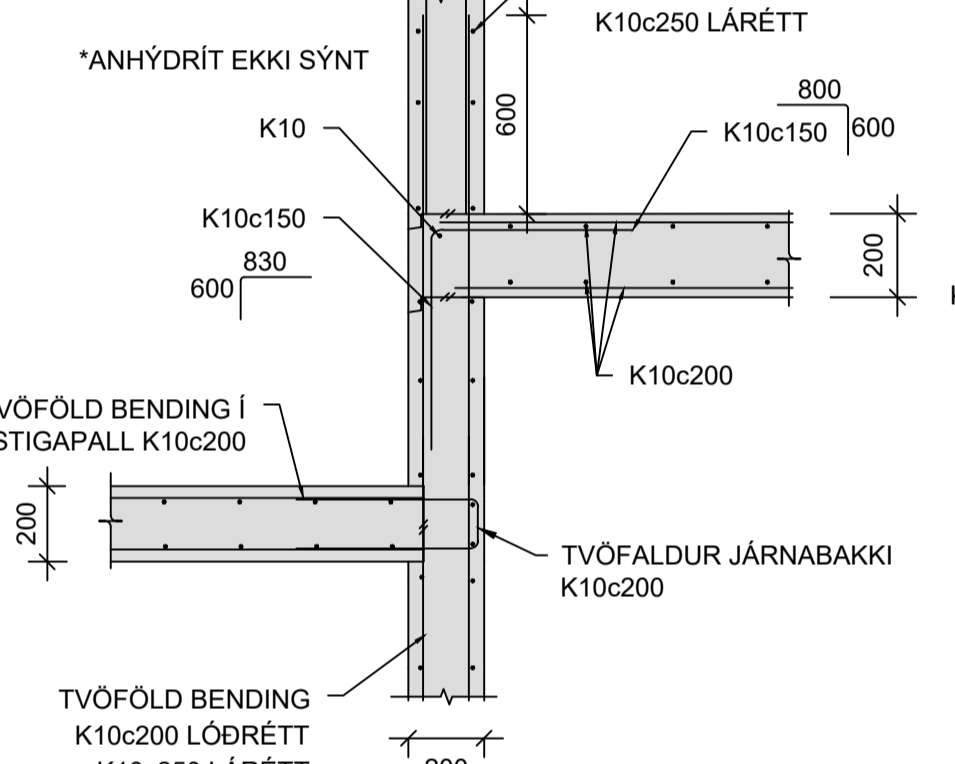
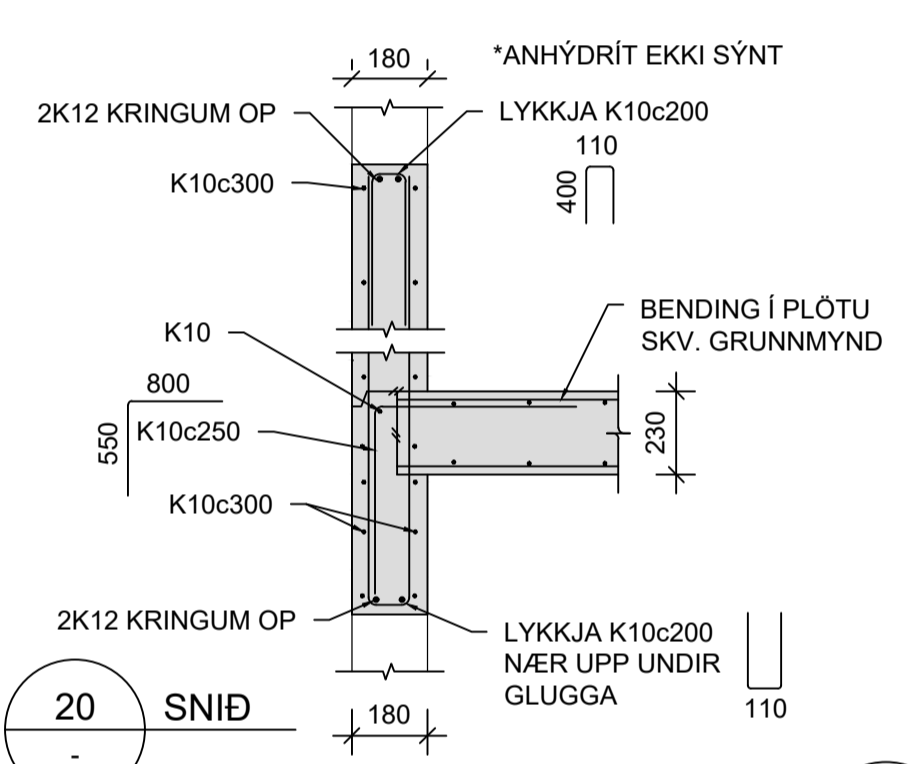
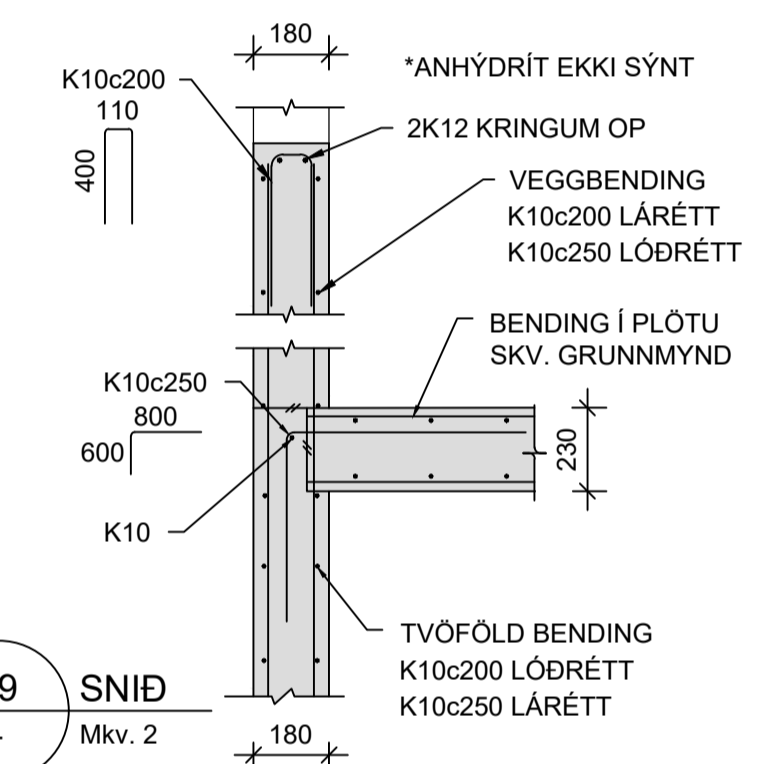
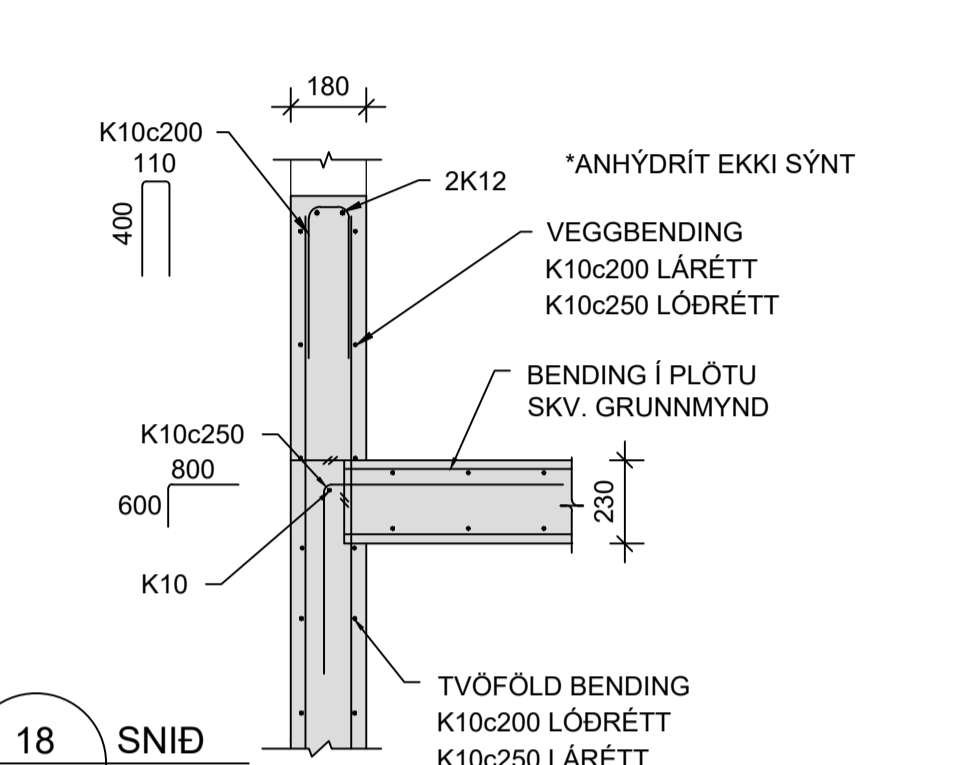
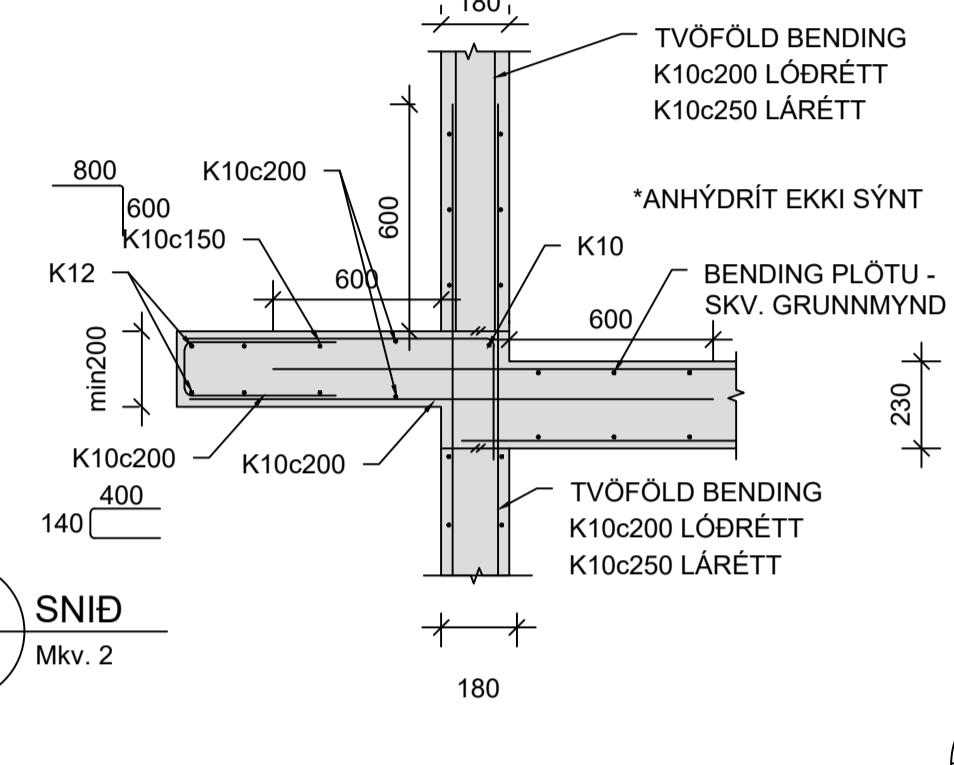
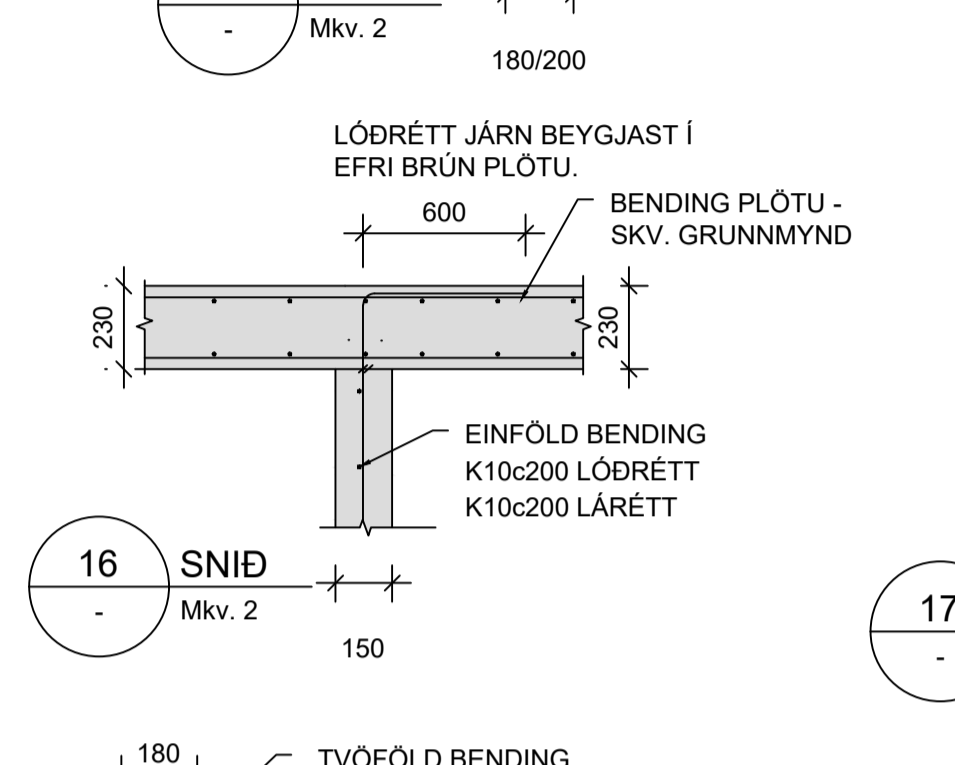
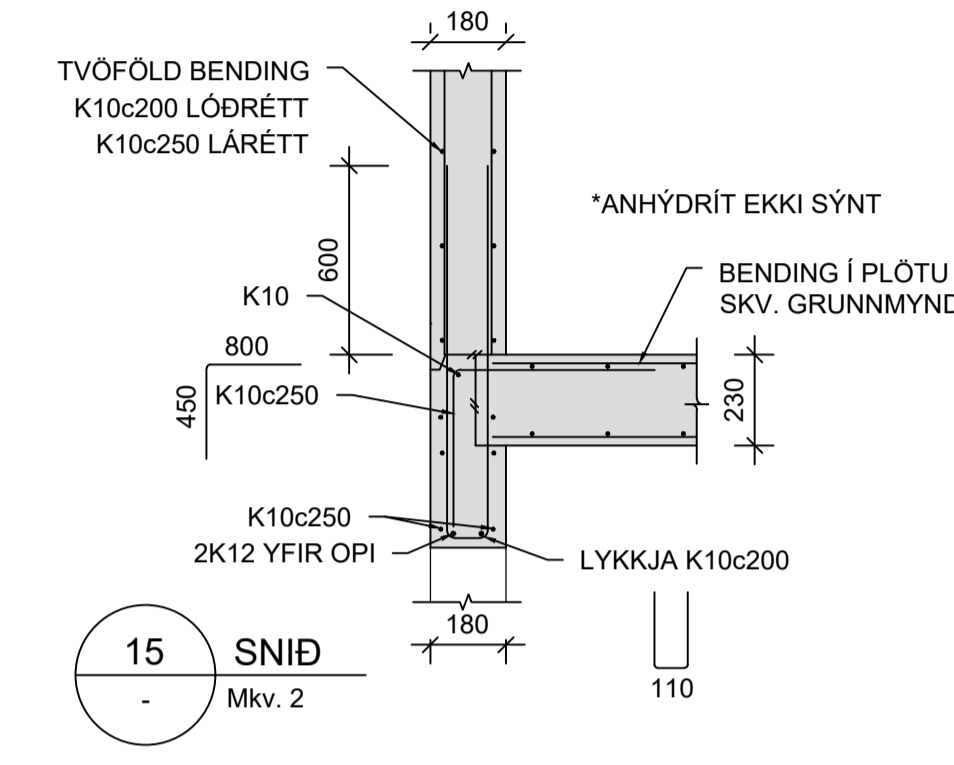
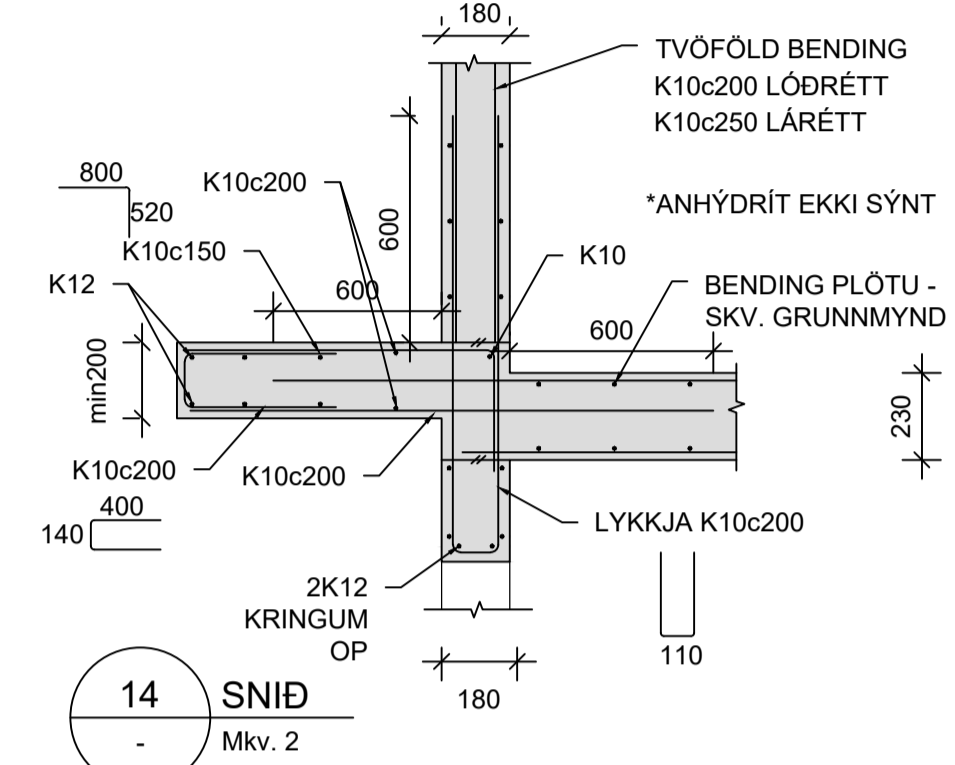
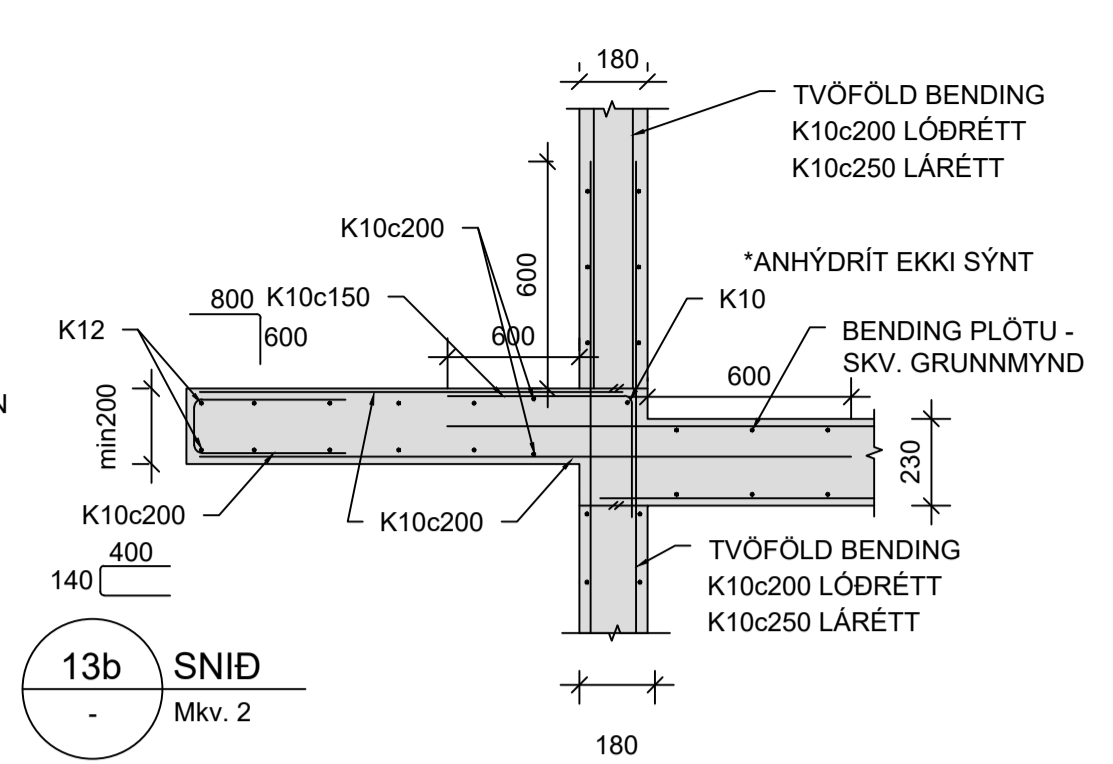
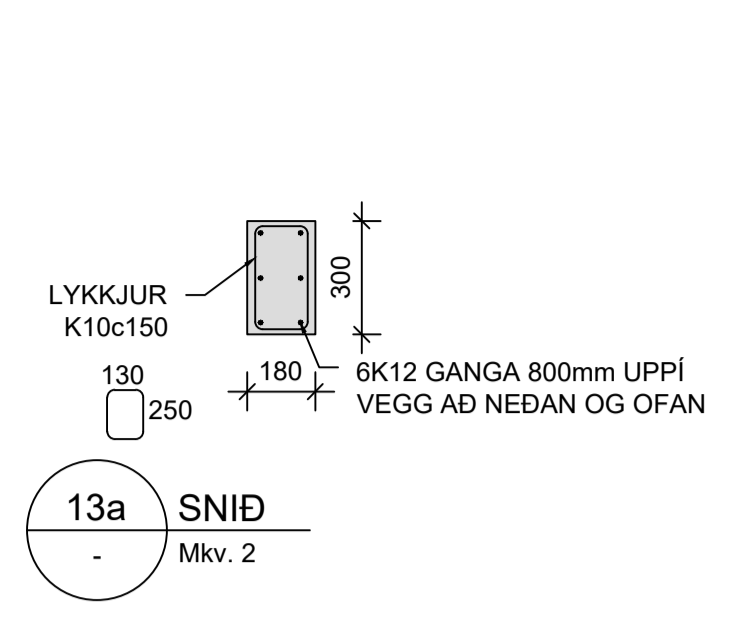
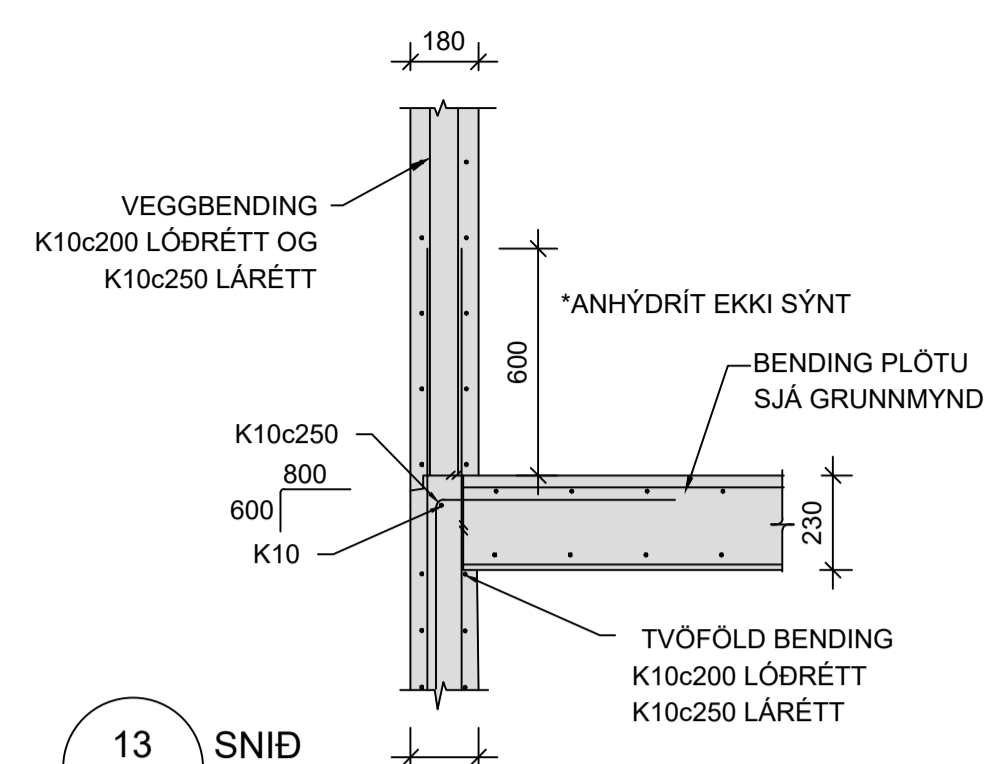
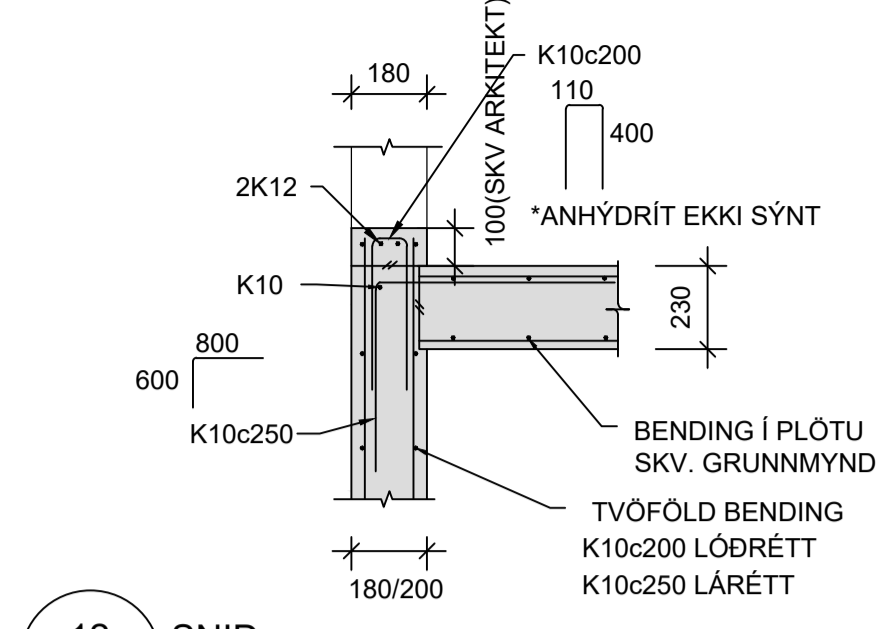
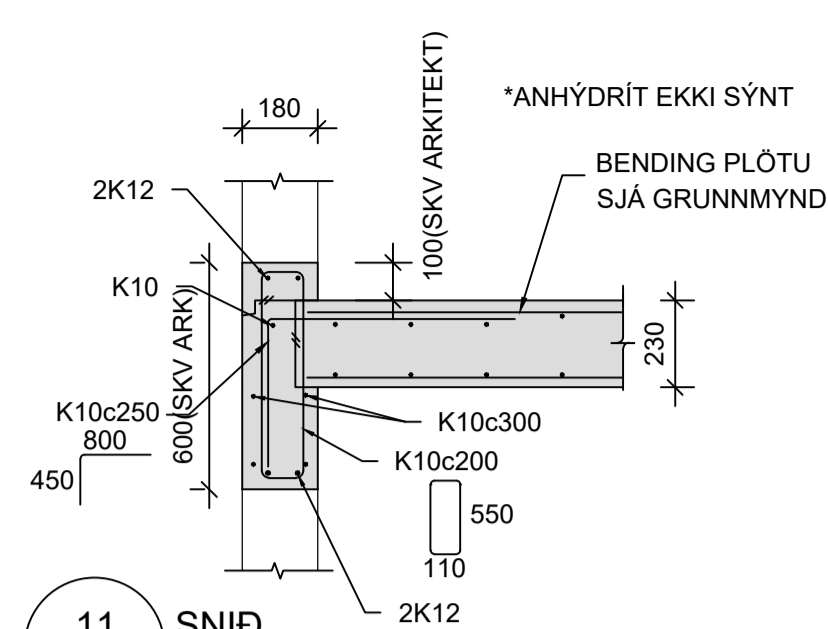

ARITUN HÖNNUNARSTJÓRA: Andri Ingólfsson Kt: 070388-3089

NR.	DAGS.	BREYTING	SP.
1	08.12.2023	FRUMÚTGÁFA	HÓO

**ÖNE VERKFRÆÐISTOFA**

ÖNE Verkefndistofa ehf. hl. 460421-0470  
HÆÐASMARI 6, 201 KÖPAVOGUR  
hoo@one.is, SÍMI 899-3577 / 899-3077

SAMPYKKT HÁKON ÖRN ÁRMARSSON 300577-3189

VERK  
HRYGGJARÁS 32  
HAFNARFJÖRÐUR

TEIKNING  
BURÐARVIRKI  
SNID OG DEILI

HANNAÐ	TEIKNAD	YFRIRAFIÐ	MÆLIKVAÐI
HÓO/SAO	SAÓ/HÓO	HÓO	1:50

DAGS. 08.12.2023 VERK NR. 23038 TEIKNING NR. B202 UTGAFANR. 1

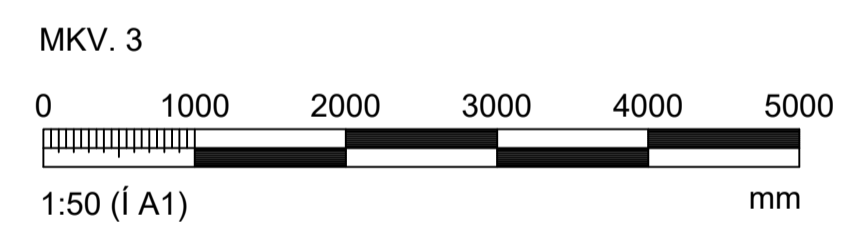
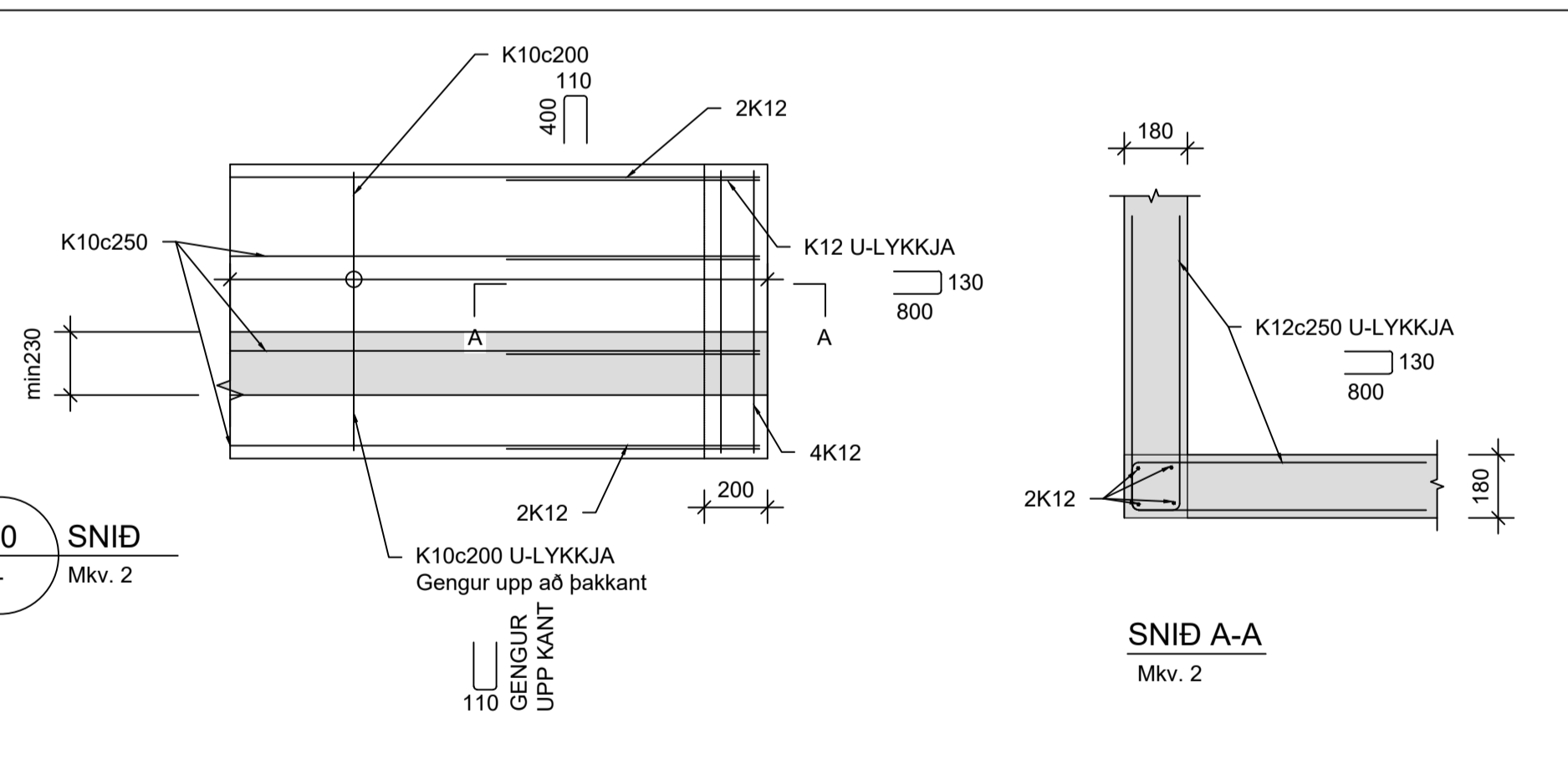
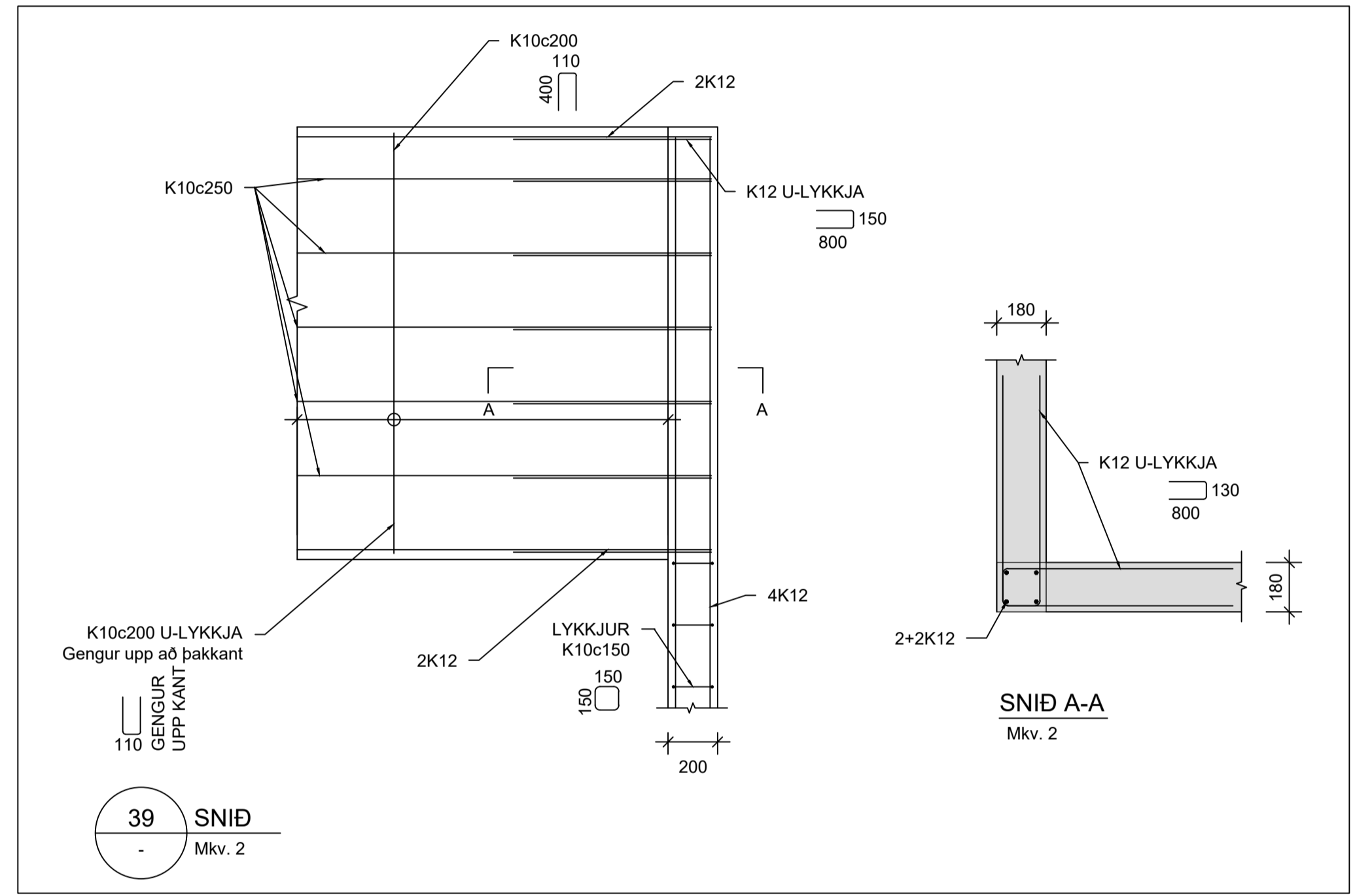
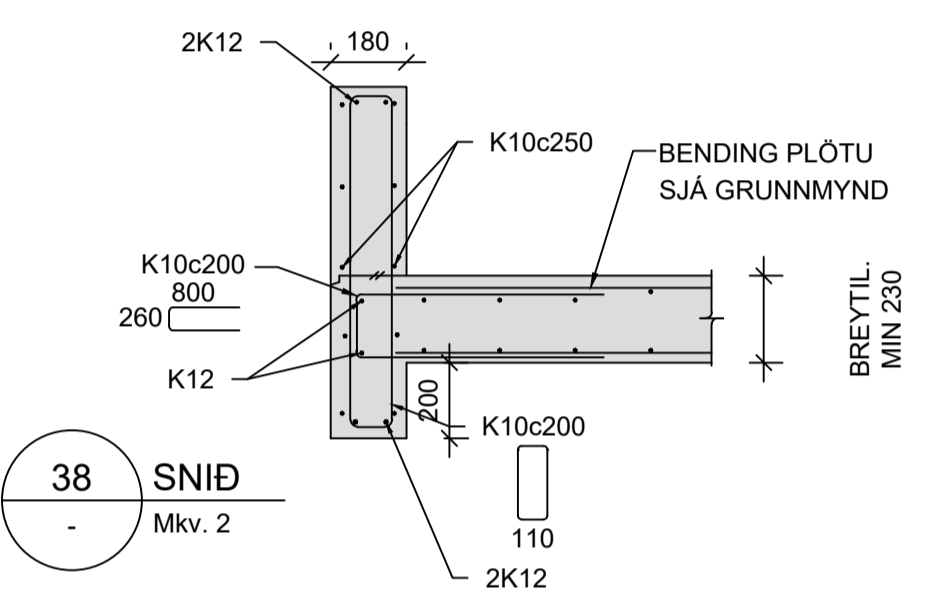
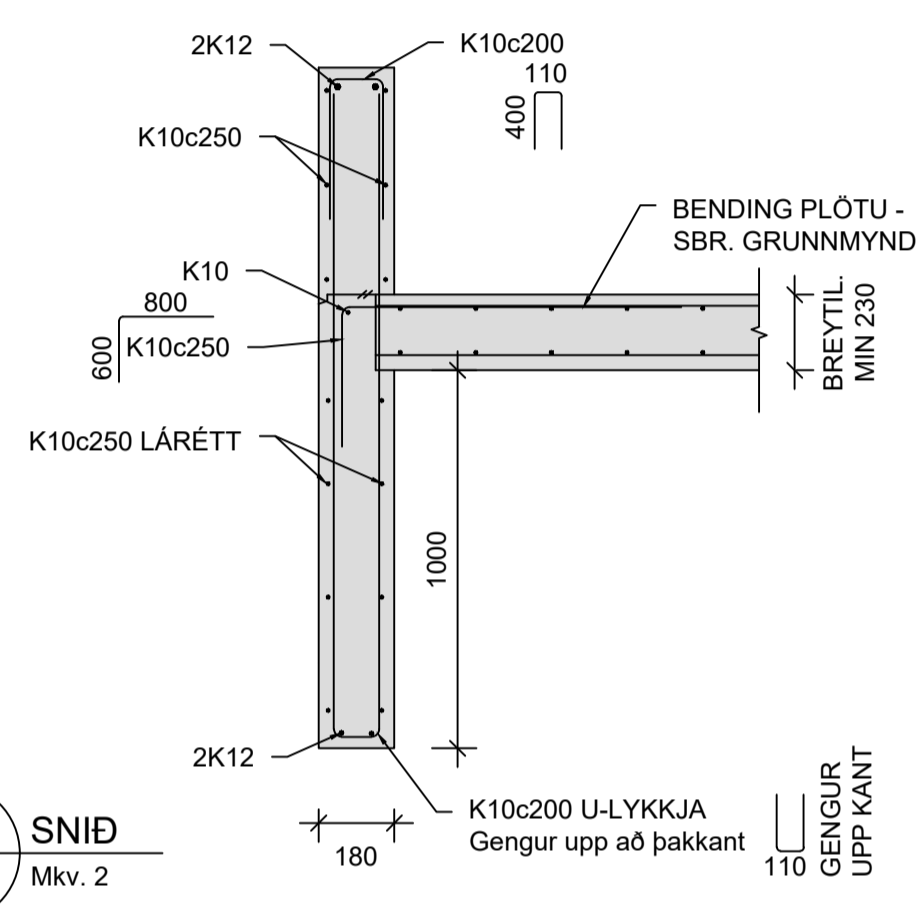
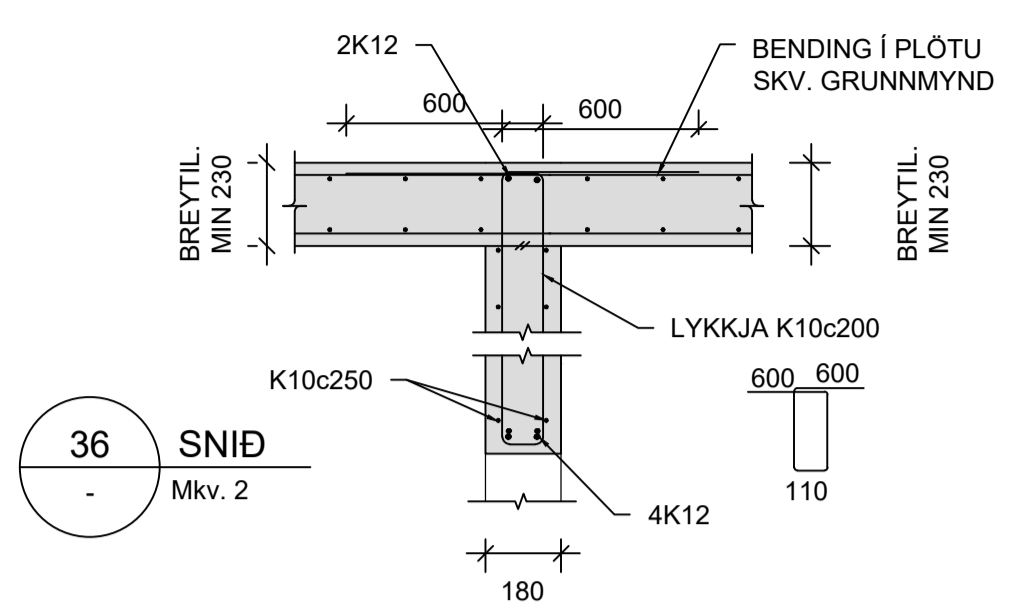
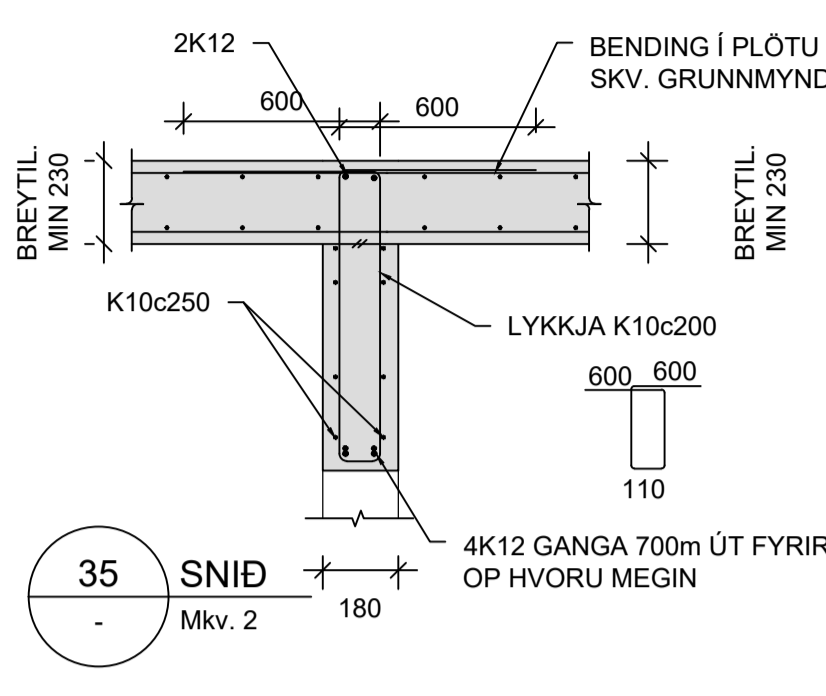
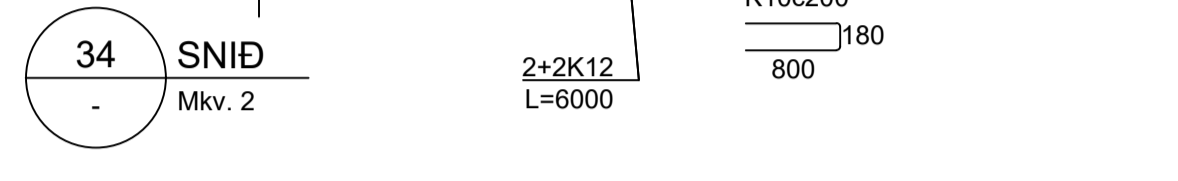
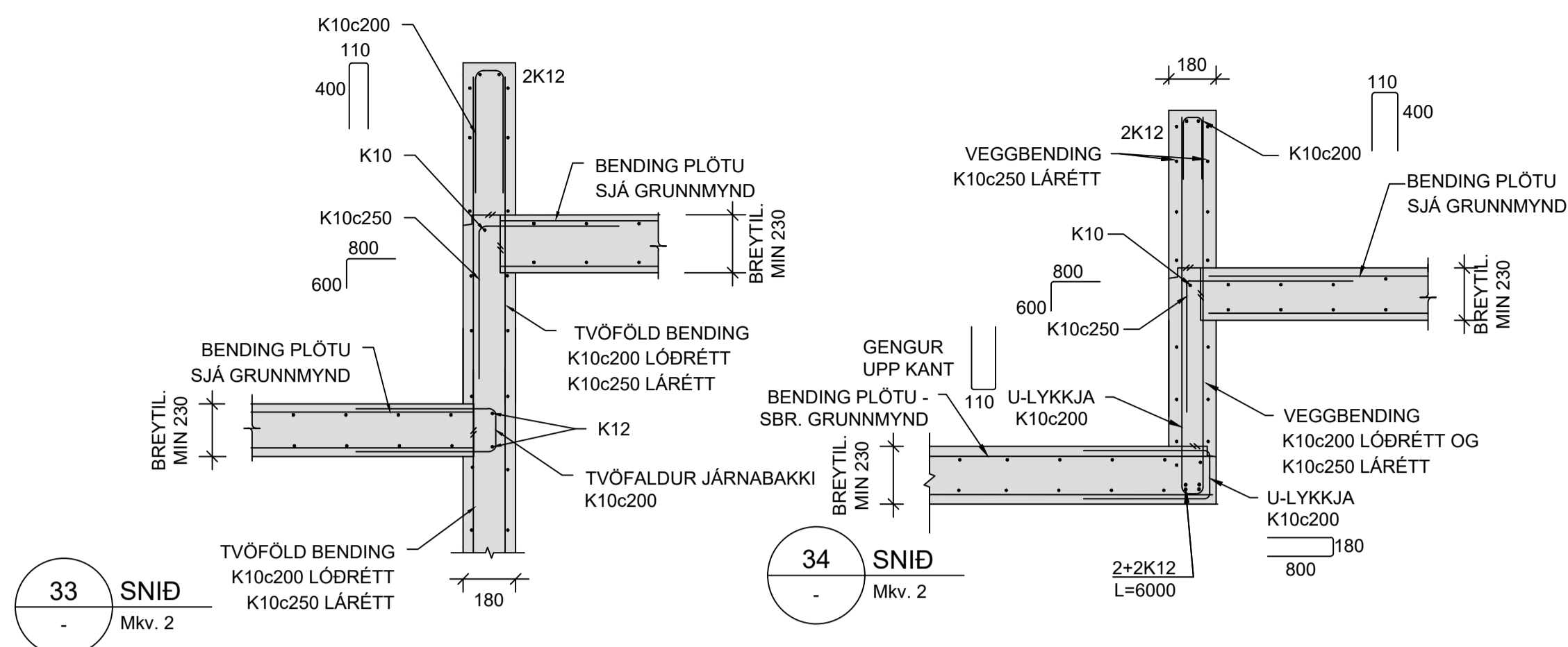

ARITUN HÖNNUNARSTJÓRA: Andri Ingólfsson Kt: 070388-3089

NR.	DAGS.	BREYTING	SP.
1	08.12.2023	FRUMÚTGÁFA	HÓO

**NNE VERKFRÆÐISTOFA**

NNE Verkefnaeistofa ehf. hl. 460421-0470  
HÆDASMARI 6, 201 KÖPAVOGUR  
hoo@nne.is, SÍMI 899-3577 / 899-3077

SAMÞYKKT HÁKON ÖRN ÓMARSSON 300577-3189

VERK  
HRYGGJARÁS 32  
HAFNARFJÖRÐUR  
TEIKNING  
BURÐARVIRKI  
SNID OG DEILI

HANNAÐ	TEIKNAD	YFIRFARID	MÆLIKVARÐI
HÓO/ SAO	SAÓHÓO	HÓO	1:50
DAGS.			UTGAFANR.
08.12.2023	VERK NR. 23038	TEIKNING NR. B203	1



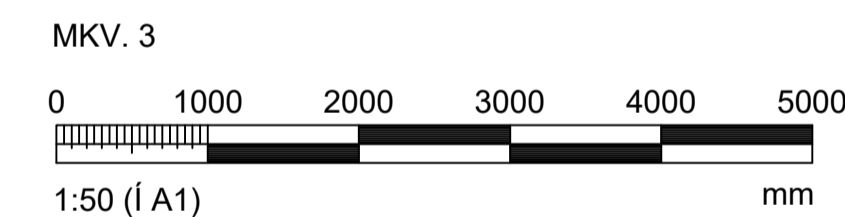
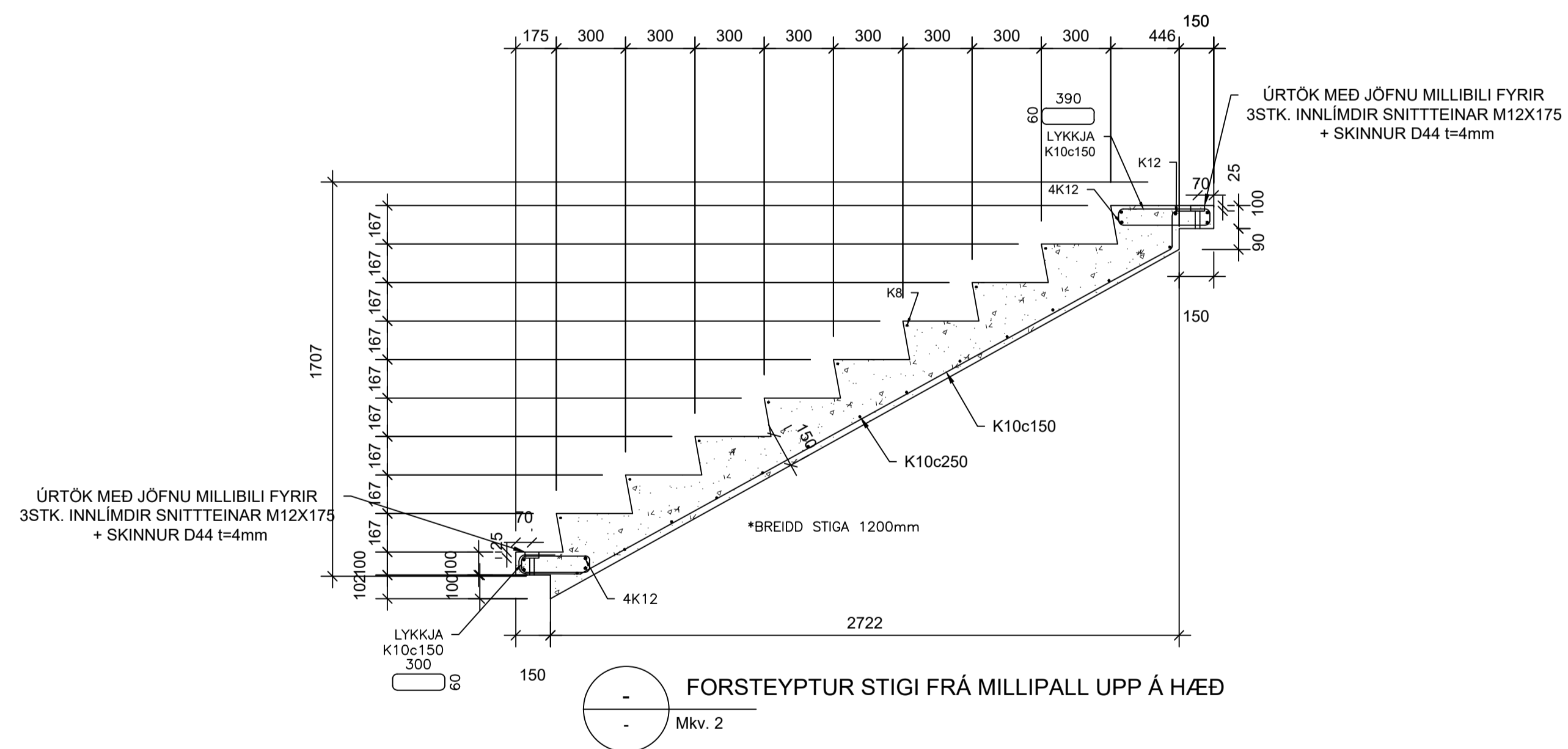
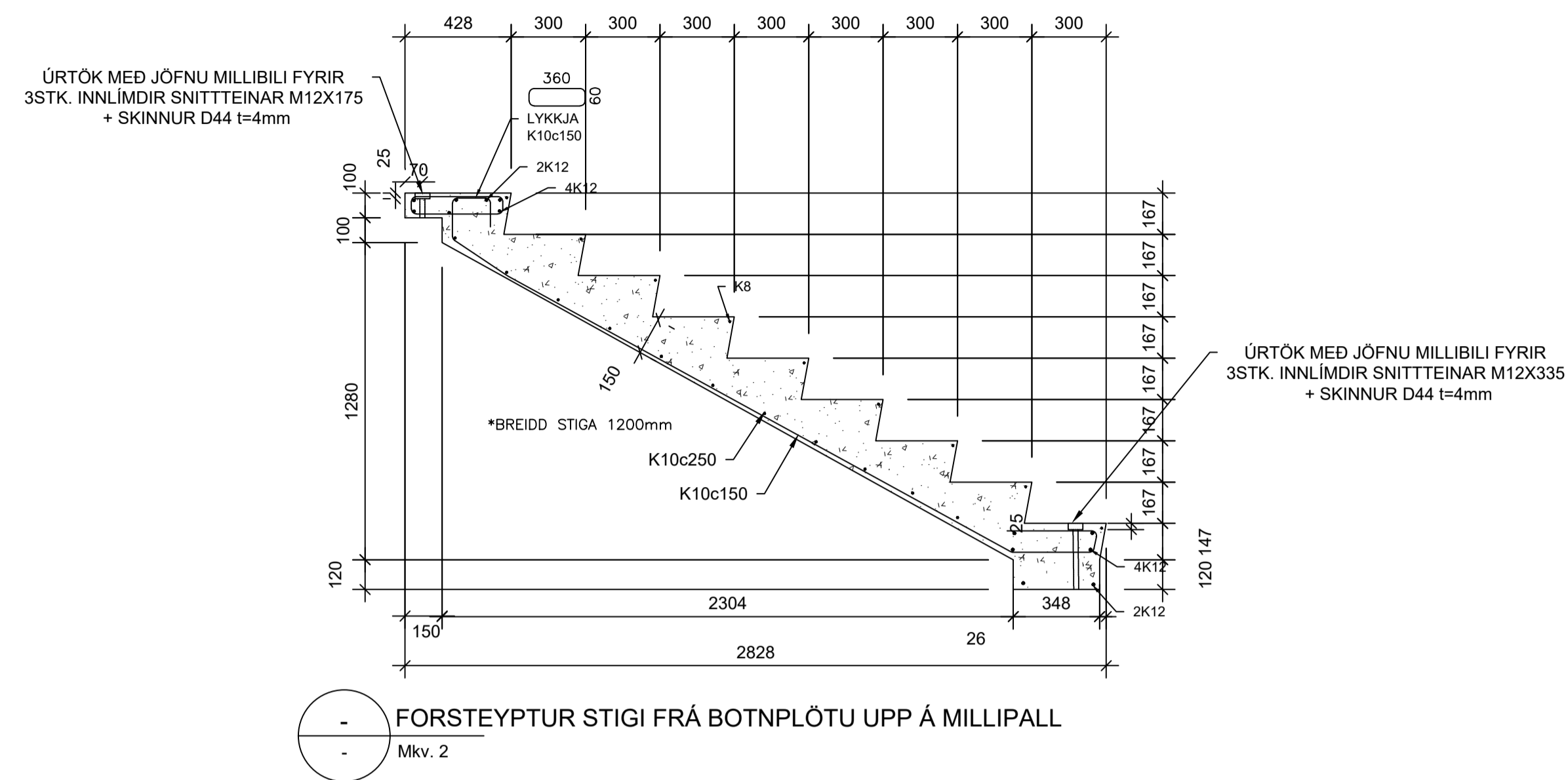

ARITUN HÖNNUNARSTJÓRA: Andri Ingólfsson Kt: 070388-3089

BREYTINGAR			
NR.	DAGS.	BREYTING	Sp.
1	08.12.2023	FRUMÚTGÁFA	HÓO

**NNE** VERKFRÆÐISTOFA

NNE Verfræðistofa ehf. hl. 460421-0470  
HÆDASMARI 6, 201 KÖPAVOGUR  
hoo@nne.is, Sími 899-3577 / 899-3077

SAMÞYKKT HÁKON ÖRN ÓMARSSON 300577-3189

VERK  
HRYGGJARÁS 32  
HAFNARFJÖRÐUR

TEIKNING  
BURÐARVIRKI  
SNIÐ OG DEILI

HANNAÐ	TEIKNAD	YFIRFARID	MÆLIKVARÐI
HÓO/ SAO	SAÓ/HÓO	HÓO	1:50
DAGS.			UTGAFANR.
08.12.2023	VERK NR. 23038	TEIKNING NR. B204	1